

EtherCAT®



# AGD155

## Standalone 240 VAC Drive

### Product Manual



[www.agito-akribis.com](http://www.agito-akribis.com)

Member of Akribis Systems group

## Revision History

Version	Description	Date
3.4	Upgraded the peak current from 20Arms to 30Arms for -10 version.	2 April 2026
3.3	Updated electrical interface connection diagrams and pinout drawings. Revised the connector pin names to match the terminal names of electrical interface connection diagrams. Corrected the analog input quantities and resolution for AGD155-EC. Corrected the Isolated digital output quantities. Updated AGD155-EC image for System Connection and Wiring. Added thermostat option to PT100 port. Deleted AqB encoder disconnected function.	3 July 2025
3.2	Updated analog inputs and outputs.	6 Dec 2023
3.1	Updated voltage specifications. Updated connector information for electrical interfaces. Added logic and bus power inrush current specifications. Added safety inputs specifications and updated Safety Circuitry. Added EtherCAT logo on cover. Various, minor text corrections.	6 June 2023
3.0	Added AGD155-EC (EtherCAT) model. Updated diagrams, improved quality of drawings and pinout diagrams. Updated X5 connector. Added analog outputs. Various, minor text corrections. Added some connector descriptions.	31 October 2022
2.3	Updated X4: Added Hall sensor circuitry. Updated X5: System I/Os connector pinout. Various, minor text corrections.	21 October 2021
2.2	Updated format for consistency with other product manuals.	18 August 2021
2.1	Updated for CE compliance. Product description revised: Standalone 240 VAC Drive. Minor text corrections.	9 June 2021
2.0	Revision of manual content and format.	3 May 2021
1.0	Initial release.	3 August 2020

## Contact Information

**Manufacturer** Agito Akribis Systems Ltd., Member of Akribis Systems Group  
**Address** 56 Serangoon North Avenue 4, Singapore 555851  
**Email** [info@akribis-sys.com](mailto:info@akribis-sys.com)  
**Website** [www.agito-akribis.com](http://www.agito-akribis.com)

## Copyright Notice

©2026 Agito Akribis Systems Ltd.

All rights reserved. This work may not be edited in any form or by any means without written permission of Agito Akribis Systems Ltd.

## Products Rights

AGDx, AGCx, AGMx, AGAx, AGIOx, and AGLx are products designed by Agito Akribis Systems Ltd. in Israel. Sales of the products are licensed to Akribis Systems Pte Ltd. under intercompany license agreement.

Agito Akribis Systems Ltd. has full rights to distribute above products worldwide.



### **Disclaimer**

This product documentation was accurate and reliable at the time of its release.

Agito Akribis Systems Ltd. reserves the right to change the specifications of the product described in this manual without notice at any time.

### **Trademarks**

Agito PCSuite is a trademark of Agito Akribis Systems Ltd..

### **Warranty**

This product is warranted to be free of defects in material and workmanship and conforms to the specifications listed in this manual, for a period of 12 months from the shipment date from factory.

## Contents

<b>1</b>	<b>Product Description</b>	<b>6</b>
1.1	General Description	6
1.2	Part Numbering	6
1.3	System Design	7
1.4	Technical Specifications	8
1.5	Environmental Specifications	12
<b>2</b>	<b>Safety</b>	<b>13</b>
2.1	Safety Symbols	13
2.2	Safety Guidelines	13
2.3	Compliance	14
<b>3</b>	<b>Installation</b>	<b>15</b>
3.1	Unpacking and Packing	15
3.2	Mounting	15
3.2.1	Mounting the AGD155	15
3.2.2	Mounting Multiple AGD155 Units	16
3.3	Electrical Installation	17
3.3.1	Power Wiring	17
3.3.2	Regeneration	18
3.3.3	Circuit Breakers	19
3.3.4	AC Line filter	19
3.3.5	Safe Operating Area (SOA)	19
3.3.6	Grounding	21
	Ground Domains	21
	Grounding Policy	22
3.3.7	PT100/PT1000/Thermostat Temperature Sensors	22
3.4	Electrical Interfaces	23
3.4.1	Interface X10: Main Power	23
3.4.2	Interface X14: I/O and Brake Power	24
3.4.3	Interface X7: Motor	25
	For Brushless Motor	25
	For Brush (or Voice Coil) Motor	25
3.4.4	Interface X15: Safety	26
	Safety Connection Diagram Example	28
3.4.5	Interface X8: Static Brake	29
	Brake Connection Diagram Example	29
3.4.6	Interface X9: Regeneration	30
3.4.7	DIP Switches	31
3.4.8	Interface X13: Ethernet (LAN)	32
3.4.9	Interfaces X11, X12 – Fieldbus	33
3.4.10	Interface X1: Micro USB	35
3.4.11	Interface X2: Main Encoder	36
3.4.12	Interface X3: Auxiliary Encoder	37
3.4.13	Interface X4: Hall Sensor	39
	Hall Sensor Connection Diagram Example	40
3.4.14	Interface X5: System I/Os	41
3.4.15	Interface X6: Control I/Os	43
	I/O Connection Diagram Example	45
	Isolated Digital Inputs 1 to 3, 5 to 11, 12 to 16	45
	Isolated Digital Input 4	46
	Isolated Digital Outputs 1 to 4, 5 to 6	46
	Differential Inputs 1 to 3	47
	Differential Outputs 1 to 4	48
	Bi-Directional Differential I/O	48



Analog Inputs 1 to 2	49
Analog Outputs 1 to 2	50

# 1 Product Description

## 1.1 General Description

The AGD155 is a 240 VAC intelligent drive with an optional EtherCAT (EoE) interface compliant with CiA 402 drive profile.

The AGD155 can drive many types of motors, such as voice coil, brushed, and brushless, including direct-drive linear and rotary motors. The drive provides numerous digital and analog inputs and outputs for application interfaces. It also supports various incremental and absolute encoders.

Advanced features include position event, position lock (capture), error mapping, dual-loop control, closed-loop force mode, and ultra-precision modes.

The AGD155 includes programming capabilities, and supports up to 8 multi-threading tasks, each of which can be configured with a different priority. It can also serve as a full-featured single-axis standalone controller.

The AGD155 also supports analog input  $\pm 10V$  current or velocity commands, and pulse and direction position commands.

Agito PCSuite software is used for configuration and tuning via an Ethernet port on the drive.



Figure 1. AGD155

## 1.2 Part Numbering

Product Description	Part Number Format
Standalone Drive	AGD155-xx-2Ayy[-CCC]

**xx:** Feature option

- **EC:** Full-featured model with EtherCAT
- **AF:** Full-featured model

**yy:** Continuous and peak current options

- **06:** 6  $A_{rms}$  continuous, 18  $A_{rms}$  peak
- **10:** 10  $A_{rms}$  continuous, 30  $A_{rms}$  peak

**CCC:** Optional customization number

Example: **AGD155-AF-2A06** indicates 6  $A_{rms}$  continuous, 18  $A_{rms}$  peak current

### 1.3 System Design

**Note:** For single-phase wiring: AC connects to L1 and L2

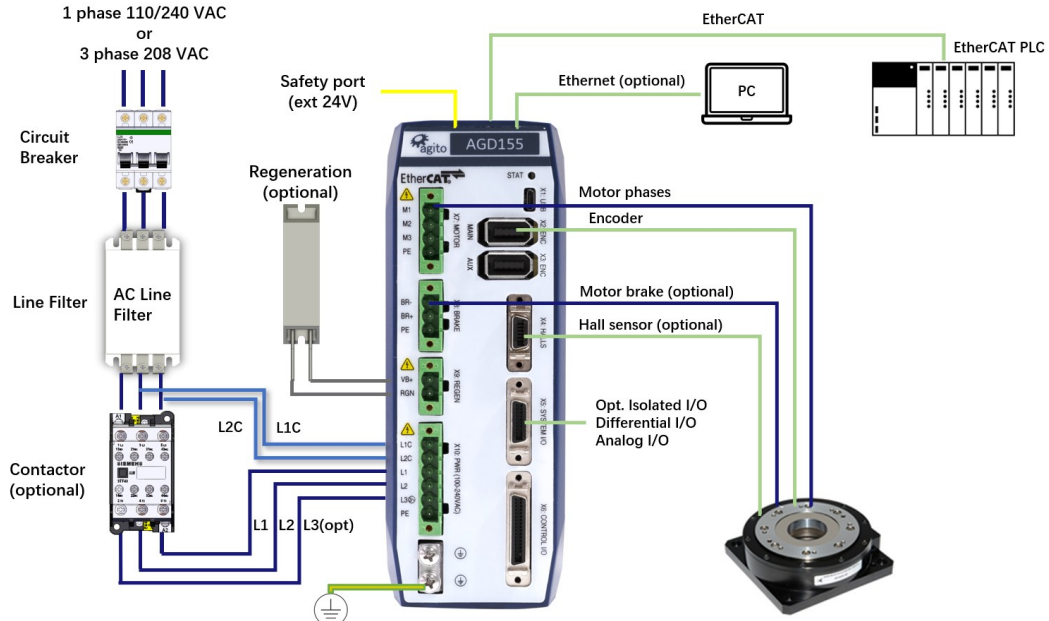

Figure 2. System Connection and Wiring (AGD155-EC)

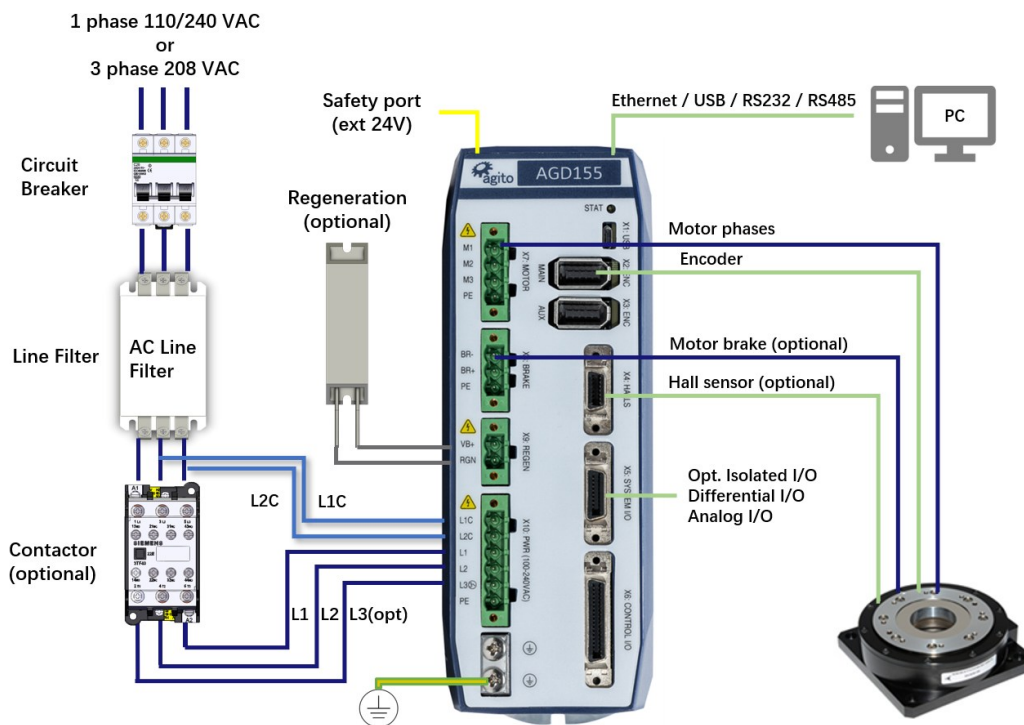

Figure 3. System Connection and Wiring (AGD155-AF)

## 1.4 Technical Specifications

### Electrical/Mechanical Specifications

Feature	AGD155-xx-2A06	AGD155-xx-2A10
Number of axes	1	
Nominal supply voltage	1-phase: 110–240 VAC L-N, 50–60 Hz 3-phase: 120 VAC L-L, 50–60 Hz	
Minimum supply voltage	1-phase: 71 VAC L-N 3-phase: 41 VAC L-L	
Maximum supply voltage	1-phase: 276 VAC L-N 3-phase, 160 VAC L-L	
Continuous output current (internally limited by firmware)	6 A <sub>rms</sub>	10 A <sub>rms</sub>
Peak output current (internally limited by firmware)	18 A <sub>rms</sub>	30 A <sub>rms</sub>
Output power @ 110 VAC	0.66 kVA	1.1 kVA
Output power @ 240 VAC	1.44 kVA	2.4 kVA
Input current @ 1-phase 110–240 VAC	9 A <sub>rms</sub>	15 A <sub>rms</sub>
Input current @ 3-phase 208 VAC	6 A <sub>rms</sub>	10 A <sub>rms</sub>
Peak current time	1.5 sec	
Output frequency	0 – 599 Hz	
Short-circuit rating	Rated short-circuit breaking capacity: 5 kA*	
Isolated digital inputs	16	
Isolated digital outputs	6	
Differential digital inputs	3	
Differential digital outputs	4	
Bi-directional differential digital I/Os (RS422)	1	
Analog inputs	AGD155- <b>EC</b> : 2 (16-bit) AGD155- <b>AF</b> : 2 (16-bit)	
Analog outputs	AGD155- <b>EC</b> : NA AGD155- <b>AF</b> : 2	
PT100/PT1000/Thermostat inputs	1 (PT1000: AGD155-EC only)	
Brake outputs	1	
Regeneration outputs	1	
Encoder ports	2	
Hall sensor ports	1	
Motor types	Voice coil, brushed or brushless linear or rotary motor. 2-phase steppers (open and closed loop, micro-stepping)	
Communication	AGD155- <b>EC</b> : EtherCAT, Ethernet, USB AGD155- <b>AF</b> : Ethernet, USB, CAN, RS232, RS485	

Feature	AGD155-xx-2A06	AGD155-xx-2A10
PWM Frequency	16 kHz	
Power supply to external devices	Voltage: 5V Overall max. current: 1.5A	
Maximum leakage current	6 mA	
AC logic power inrush current	Max current: 2A Max duration: 1 ms	
AC main power inrush current	Max current: 7.8A Max duration: 20 ms Note: controlled by soft start	

\* During compliance testing, the short-circuit current was 200A

### Encoder Ports Specifications

Feature	Specification
Encoder types	Incremental AqB, Sin/Cos Absolute: EnDat 2.2, BiSS-C
Power supply to encoder	0.5 A per encoder port
Max. cable length	40 m
Incremental encoder	Hardware: Differential RS422/RS485 Max. input frequency: 6.25 MHz Termination: 120 Ω Commutation: Auto-phasing, Hall sensor
Sin/Cos encoder (available on Main Encoder port only)	Hardware: Differential RS422/RS485, 1V pkp @2.5V Max. input frequency: 250 kHz Termination: 120 Ω Max interpolation: 13 bits (x 8192) Commutation: Auto-phasing, Hall sensor
Absolute BiSS-C	Hardware: Differential RS422/RS485, clock (MA), data (SLO) Clock frequency: 1 MHz Max. position bits: 32 bits Commutation: Auto-phasing, by absolute offset
Absolute EnDat 2.2	Hardware: Differential RS422/RS485, clock, data Clock frequency: 1 MHz Max. position bits: 32 bits Commutation: Auto-phasing, by absolute offset
Hall sensor	Opto-isolated 5V with internal or external power supply

I/O Specifications

Feature	Specification
Power supply for optically isolated I/Os	Voltage: 5–28 VDC
Optically isolated digital inputs	Type: PNP/NPN Propagation delay: 10 $\mu$ s Max. frequency: 100 kHz Functionality: limit switches, home, captures, start motion, gain scheduling, and others
Optically isolated digital outputs	Type: Sink/Source Max current: 0.5A (for Sink type), 0.3A (for Source type) Propagation delay: 10 $\mu$ s Max. frequency: 100 kHz Functionality: alarm, in-position, event (PEG), and others
Differential inputs	Hardware: Differential RS422 Termination: 120 $\Omega$ Propagation delay: 100 ns Max. frequency: 5 MHz Functionality: Position lock (capture), pulse and direction, AqB encoder following, Handwheel
Differential outputs	Hardware: Differential RS422 Termination: NA Propagation delay: 100 ns Max. frequency: 5 MHz Functionality: Position event, encoder emulation, alarm, statuses, and others. Differential output voltage: 3.3 VDC
Bi-directional differential I/O	Hardware: Differential RS422 Termination: 120 $\Omega$ Propagation delay: 100 ns Max. frequency: 5 MHz Direction: Input or output, set by Agito PCSuite Functionality: Any differential input or output functionality. Bi-dir differential output voltage: 2.3 VDC
Analog inputs	Operational voltage: $\pm$ 12V Resolution: 16 bits
Analog outputs	Operational voltage: $\pm$ 12V Resolution: 16 bits
Safety inputs	2 independent inputs Voltage: 5–28 VDC
Static brake output	Operational voltage: 24V Maximum current: 3A
Temperature sensors inputs	PT100, PT1000 or Thermostat. Refer to the section PT100/PT1000/Thermostat Temperature Sensors.



## 1.5 Environmental Specifications

---

### Environmental Specifications

Feature	Specification
Operating temperature*	AGD155-xx-2A06: 0°C to 50°C AGD155-xx-2A10: 0°C to 40°C
Storage temperature	-20°C to 70°C
Operating humidity	< 90%
Storage humidity	< 40%
Pollution degree	2
Vibration	1G @ 150 Hz according to IEC 60068-2-6
Operating conditions	Protection class: IP20

\* The operational range may be additionally limited by the internal temperature protection of the product. Refer to the section Safe Operating Area (SOA). However, it is the user's responsibility to avoid operating the product in environmental conditions that do not conform to the defined limits.



## 2 Safety

### 2.1 Safety Symbols

Safety symbols indicate a potential for personal injury or equipment damage if the prescribed precautions and safe operating practices are not followed.

The following safety symbols are used in the product documentation.

#### Safety Symbols

Symbol	Meaning	Description
	Hazardous voltage	Indicates hazards arising from dangerous voltages.
	Earthing PE (protective earth)	Identifies any terminal which is intended for connection to an external conductor for protection against electric shock in case of a fault, or the terminal of a protective earth (ground) electrode.
	Caution, hot surface	Indicates the marked item can be hot and should not be touched without taking care.

### 2.2 Safety Guidelines

To achieve optimum and safe operation of the product, it is important to follow the safety procedures specified in this manual.

Only qualified personnel may install, maintain, or repair the product. Before starting installation, maintenance or operation, ensure that all system components are connected to protective earth ground (PE).

The PE wire must be colored green-yellow, in accordance with local electrical wiring standards.

This product contains electrostatic-sensitive components. Proper handling procedures must be observed to avoid damage to the product.

To avoid electric arcing and hazards, never connect or disconnect any connector while the power source is on.

The maximum power supply voltage connected to the product must comply with the ratings provided in this manual.

Always disconnect the power cables before servicing the product.

Pay attention to safety symbols on the product or in the manual. Follow proper safety precautions when installing or operating the product.



#### Attention

All power connectors must be securely tightened before any operation.



#### Warning

Connectors X10, X9, and X7 are high power. Do not touch these connectors when the product is powered.

## Safety



### Warning

Capacitors on the DC bus can retain hazardous voltages after input power has been removed. Discharge time to below 60 VDC is 10 minutes.

Wait until the red LED (charge indicator) shuts off before physically touching the product. The product must not be opened or serviced until the discharge is complete. Failure to observe this precaution could result in severe bodily injury or loss of life.



### Attention

Do not attempt to hinder or override the product's or system's fault detection or protection circuits. You must determine the cause of a fault and correct it before you attempt to operate the system. Failure to correct the fault could result in personal injury and/or damage to equipment.

## 2.3 Compliance

### Standards Compliance

Description	Standard
Safety requirements – Electrical, thermal and energy	IEC-61800-5-1
EMC requirements and specific test methods	IEC-61800-3

This product is intended to operate in a machine or equivalent end-product. The machine or end-product must comply with any necessary safety standard as typically required for the same type of machine or end-product. It is the responsibility of the machine or end-product manufacturer to ensure the final machine or end-product meets the requirement of any safety and EMC regulations.

## 3 Installation

---

### 3.1 Unpacking and Packing

---

Save the original box and packing materials in case you need to pack and return the product to the manufacturer.

To unpack the product:

1. Carefully remove the product from the box and the packing materials.
2. Visually inspect the product to ensure that there is no damage. If any damage has occurred, report it immediately to the carrier that delivered the package.
3. After unpacking, locate the part number label on the product, and make sure it matches the product you ordered, and that the voltage meets your specific requirements.

### 3.2 Mounting

---

#### 3.2.1 Mounting the AGD155

---

The heatsink on the back of the AGD155 includes a hole (at top) and a slot (at bottom) for mounting the unit. The AGD155 must be mounted vertically (book mounting), as shown in Figure 5.

The AGD155 is mounted using 2 M4 screws. It is important to mount the product on metal panel for both grounding and secure connections.

The heatsink of the AGD155 is electrically conductive and serves as the protective earth (PE) ground of the product. However, it is critical to ensure the PE screws are electrically conducting between the PE of AGD155 and the PE of main power supply in the system.

All cables connected to the product must be securely constrained to avoid vibration that causes stress concentration at the cables or connectors which may result in breakage of electrical conductivity.



#### Warning – Metal Base Plate for Heat Dissipation

---

The product is supplied with the mounting plate built into the heatsink. At full power operation, the heatsink can be quite warm, around 45°C. It is recommended to mount the product on a large metal panel to help dissipate the heat generated in the product.

## Installation

### 3.2.2 Mounting Multiple AGD155 Units

When mounting multiple AGD155 units within a cabinet, clearance between units must be at least 10 mm. In addition, top and bottom clearance must be at least 50 mm.

Ambient temperature in the cabinet must not exceed the limit defined in section Safe Operating Area (SOA).

If units are mounted on a backplane, the backplane temperature must not exceed the limit defined section Safe Operating Area (SOA).

It is recommended to install a cooling fan at the bottom of the cabinet for best circulation.

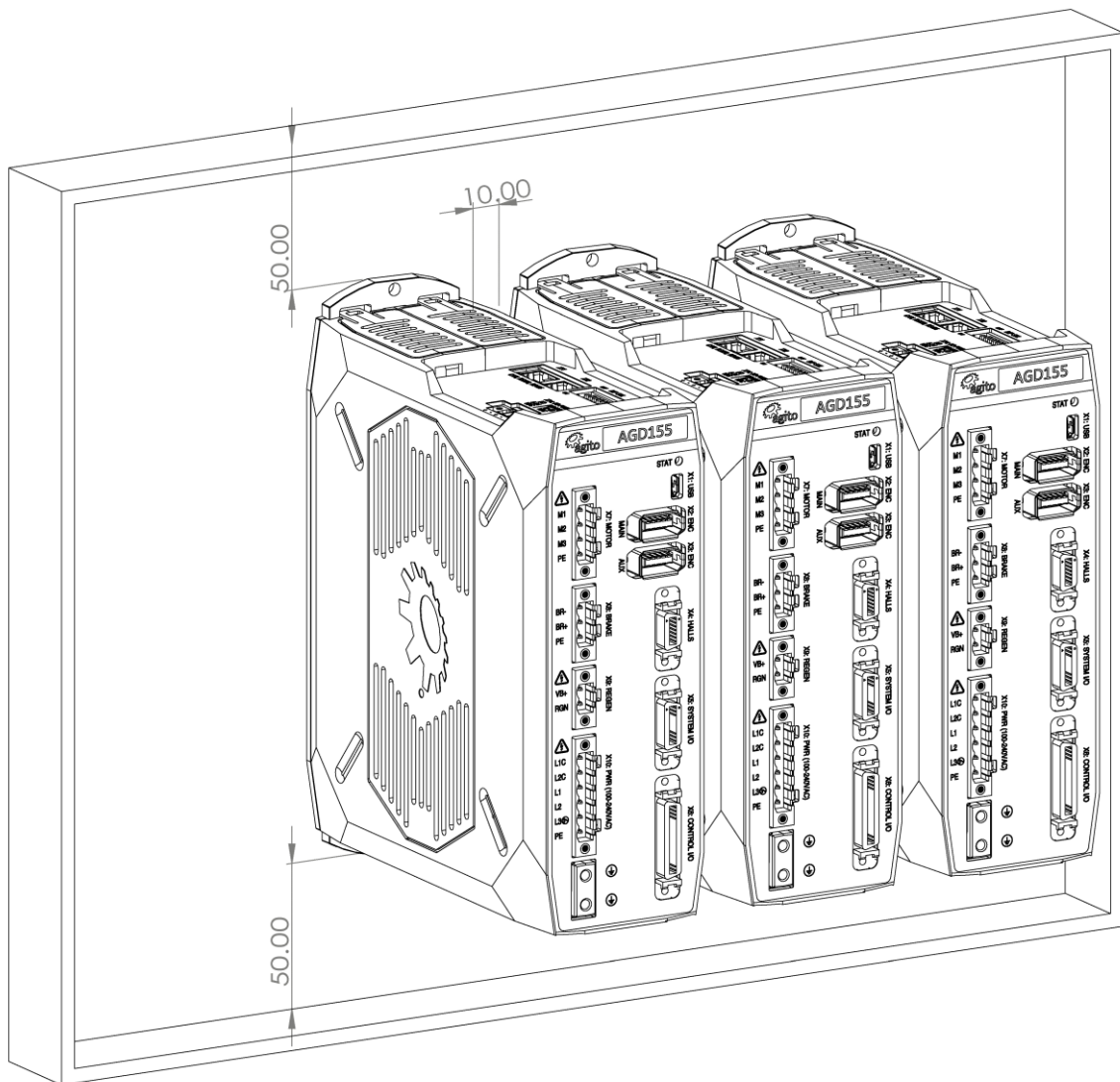

Figure 5. Mounting Multiple Units within Cabinet

### 3.3 Electrical Installation

#### 3.3.1 Power Wiring

AGD155 is designed to operate directly from 110 VAC to 240 VAC mains power, which is supplied to bus voltage, motor, and logic power.

Logic power input (L1C, L2C) uses 1-phase 110–240 VAC input.

Motor power input (L1, L2, L3) uses either of the following:

- 1-phase 110–240 VAC input
- 3-phase 208 VAC input



**Note – Wiring**

In single phase wiring, L1 and L2 must be wired to 1-phase 110/240 VAC.

In three phase wiring, L1, L2 and L3 must be wired to 3-phase 208 VAC.

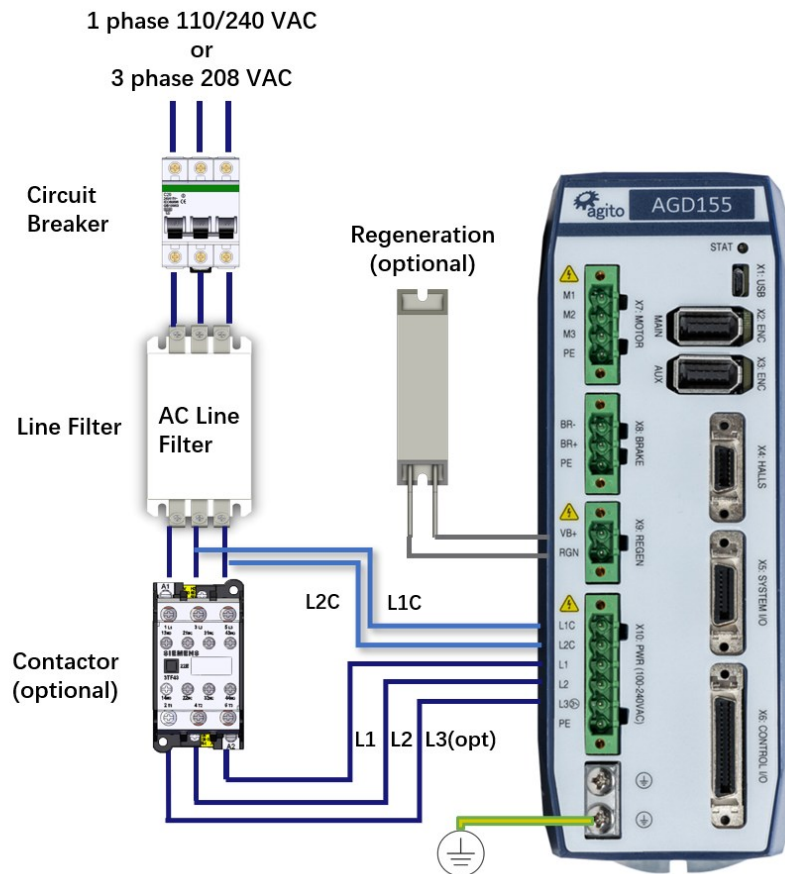

Figure 6. Power Supply Wiring

### 3.3.2 Regeneration

---

AC power input is converted to DC bus, and outputs a controlled electrical power through the phases of the motor. The motor converts this electrical power to a mechanical power that moves the load.

During motor deceleration and stopping, the inertia of the load drives the movement of the motor, not the servo drive. Due to back EMF, the motor acts as a generator and returns energy to the DC bus supply, which causes the DC bus voltage to increase to undesirable level.

Maximum allowable DC bus voltage is 390 VDC. To control the DC bus voltage, a regeneration resistor can be connected to the servo drive to dissipate excess regenerated energy and prevent it from reaching undesirable levels. The regeneration resistor starts to dissipate energy at 370 VDC (default); this value is user-configurable.



#### Warning

---

DC Vbus is monitored, and motors will be disabled if voltage is too high. However, there is no protection against the connection of an excessive voltage power supply that will damage the product.

For connection details, refer to the section *Interface X9: Regeneration*.

#### Important Notes

- The regeneration feature, once enabled, is always active, regardless of the motor status (enabled/disabled).
- Current will flow in the regeneration resistor depending on the values of RegenOn and RegenOff, and the power supply voltage.
- There are no current or power protections to protect the regeneration resistor or the internal MOSFET.
- Be sure to set the suitable regeneration parameters for the supply voltage and the external regeneration resistor.
- Plug in the regeneration resistor only after all parameters are set properly, and always when the controller power is off.
- Let the regeneration resistor cool down before touching it. Unplug it only when the controller power is off.
- During development, if the supply voltage is to be modified, first disconnect the regeneration resistor and, before reconnecting the regeneration resistor, be sure to adjust the regeneration parameters to match the new supply voltage.
- We recommend adding external protections (such as PTC) to protect the regeneration resistor.

### 3.3.3 Circuit Breakers

#### Circuit Breaker Specifications

Feature	Specification
Circuit breaker type	Type C. 2-pole for L to N. 3-pole for 3-phase.
Fuse type	Time delay / slow blow
Current rating	AGD155 10A: 25 A AGD155 6A: 10 A
Voltage rating AC	600 VAC
Interrupt rating	minimum 10 kA

**Example:** Schneider Electric iC60N 3P 6A C

### 3.3.4 AC Line filter

For proper product operation, an external AC line filter is recommended according to the application. Refer to Figure 6. The AC line filter prevents external transients and spikes on the power line from entering the product enclosure. Such interference may be caused by other AC powered devices being turned on and off, and by motors running on the same power subsystem.

#### AC Line Filter Specifications

Feature	Specification
Filter type	2-stage AC line filter
Current	20 A
Voltage	250 VAC
Antennation frequency	From 100 kHz to 50 MHz

**Example:** Würth Elektronik 810913020

### 3.3.5 Safe Operating Area (SOA)

While each specific maximal rating can be safely used, the product cannot support certain combinations of these maximal ratings. For example, the product will not enable operation under the following **combined** maximal ratings usage continuously over long-term period:

- Continuous current at  $6A_{rms}$ , at 90% PWM duty cycle
- 1.5A external load on the 5V supply
- Product mounted horizontally and not attached to a suitable base plate
- 55°C ambient temperature

Permitted combinations, as well as forbidden combinations, cannot be specifically provided since they are a function of multiple conditions, such as continuous current, bus voltage, PWM duty cycle, 5V consumption, I/O's high current usage, mounting base plate size, product mounting orientation, and ambient temperature.

The SOA of the product is defined as any combination of operational conditions (each within the absolute maximal ratings defined in the Technical Specifications) and assembly options that lead to internal product temperature below 80°C.

The product includes a built-in temperature sensor. Its internal temperature is reported via the status parameter PwrTemp (integrated power module temperature). When PwrTemp reaches 80°C,

## Installation

the motor will be disabled and an error will be reported. A motor-enable request will create an error if PwrTemp is higher than 80°C.

The following figure shows examples of safe operating cases for AGD155-xx-2A06. The SOA charts assume 90% duty cycle on PWM output continuously; that is, motors are moving at the maximum speed allowed by the bus voltage.

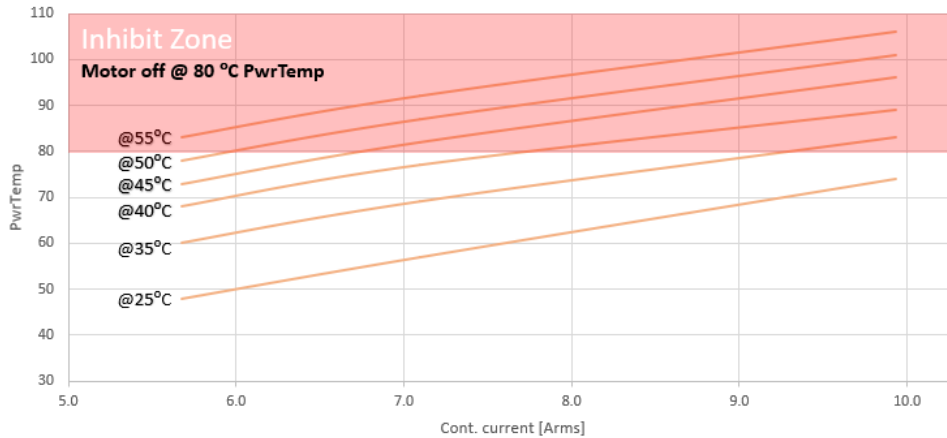

Figure 7. Current/Temperature



### Attention

Each of the power/voltage/current absolute maximal ratings is valid over the overall operating temperature range, subject to the safe operating area (SOA).



### Attention

Operating (or storing) the product contrary to the defined absolute maximal ratings is not allowed and will damage the product.

## Installation

### 3.3.6 Grounding

It is recommended to install the AGD155 on a metal plate for better power dissipation, reduced EMI, and grounding connection. Make sure the plate is not painted.

The heatsink of the AGD155 is electrically conductive and serves as the protective earth (PE) ground of the product. However, it is critical to ensure the PE screws are electrically conducting between the PE of AGD155 and the PE of main power supply in the system.

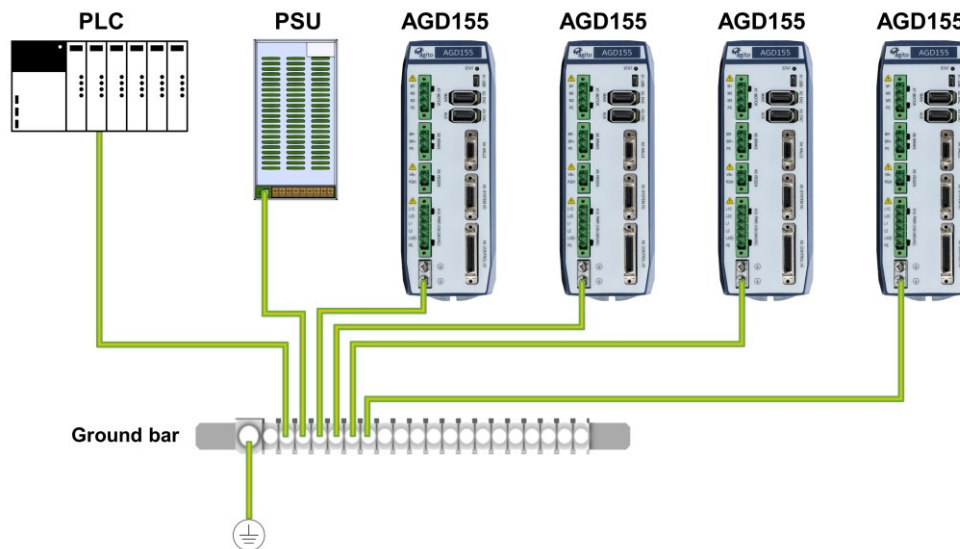

Figure 8. System Grounding

### Ground Domains

The following table shows the ground domains in the AGD155 system:

- GND. Reference voltage for digital/analog circuits and signals.
- PGND. High voltage ground domain (internal)
- General. Usually at DC potential close to GND, but not connected internally.

#### Ground Domains

Name	Ground Domain	Notes
DC power input	GND (I/O return)	External DC power supply
AC power input	PGND (power ground only)	Internal PGND
Isolated digital inputs/outputs	General	Isolated
Differential inputs/outputs (not isolated)	GND	To controller/PLC
Analog inputs/outputs (not isolated)	GND	
Brake control output	General	External DC power supply
Regeneration output	PGND	External shunt resistor
Ethernet communication	General	Isolated
Other communication	GND	Not isolated (unless otherwise stated in manual)

## Grounding Policy

Grounding of the product must comply with the following guidelines:

- The enclosures and other external parts that may be touched by the user are in the **safe domain**.
- The AGD155 must be connected to protective earth (PE) and connected to the building's ground. PE is protected with an earth-leakage circuit breaker (ELCB); hence it is safe to touch. Refer to Figure 6.
- PGND is connected directly to mains wires, hence it is just as dangerous as mains to the user.
- All shielded cables, including but not limited to motor, encoders, and power input, have their shield connected to PE as part of the external metal enclosure.
- PGND is bypassed to PE with low capacitance (around 10 nF) for EMI/EMC purposes.
- It is critical to avoid ground loops in the system. A ground loop allows currents to return by two or more different paths, causing electromagnetic interference or even damage to wires.
- The system designer must carefully examine all GND connections in the system to ensure that no loops are created, and that all GND-referenced signals have a GND wire nearby (for both return currents and common mode voltage).

### 3.3.7 PT100/PT1000/Thermostat Temperature Sensors

AGD155-EC supports three types of temperature sensors:

- The PT100 temperature sensor is a platinum resistance thermometer. Its resistance value at 0°C is **100Ω**.
- The PT1000 temperature sensor also is a platinum resistance thermometer. Its resistance value at 0°C is **1000Ω**.
- The thermostat is an over-temperature protection device that monitors the motor coil temperature. It remains closed during normal operation and opens its contact when the temperature exceeds a defined limit to protect the motor from overheating damage.

AGD155-AF only support PT100 and thermostat temperature sensors.

The temperature sensor is wired to the X4 connector as shown in the following table.

#### PT100/PT1000/Thermostat Temperature Sensor Wiring

Pin #	Pin Name	PT100	PT1000 (AGD155-EC only)	Thermostat
3	PT1000_EN	NC	Short to pin 6	NC
6	GND	NC	Short to pin 3	NC
8	Temp+	PT100+	PT1000+	Thermostat+
9	Temp-	PT100-	PT1000-	Thermostat-

### 3.4 Electrical Interfaces

This section provides a detailed description of all the power and signal interfaces of the AGD155.

#### 3.4.1 Interface X10: Main Power

Connector X10 is used to supply AC power to the AGD155.



Supply voltages for the AGD155 are as follows:

- Nominal supply voltage: 1-phase: 110–240 VAC L-N, 50–60 Hz  
3-phase: 120 VAC L-L, 50–60 Hz
- Minimum supply voltage: 1-phase: 71 VAC L-N  
3-phase: 41 VAC L-L
- Maximum supply voltage: 1-phase: 276 VAC L-N  
3-phase, 160 VAC L-L

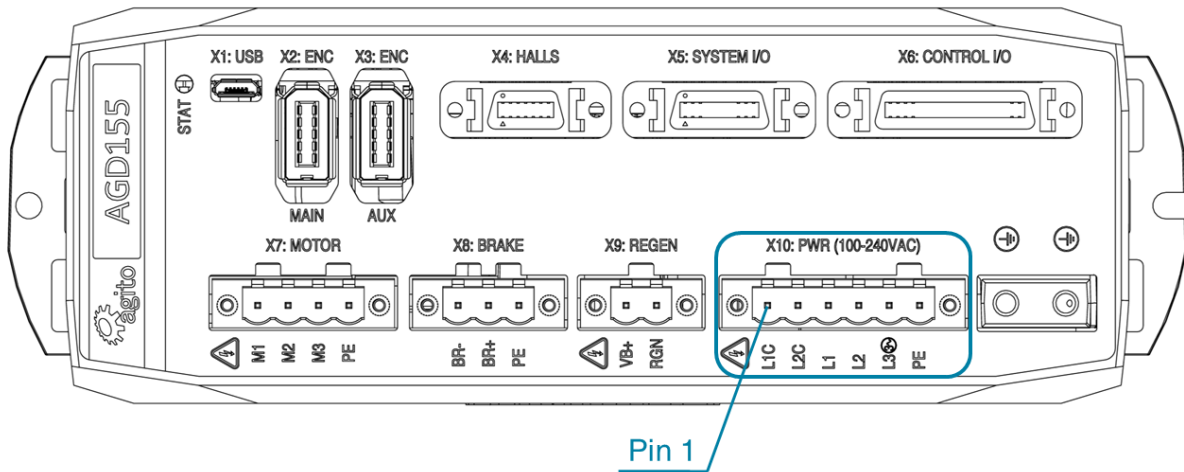

Figure 9. Power Connector

#### Connector X10: PWR

Pin #	Name	Description
1	L1C	AC logic power
2	L2C	AC logic power
3	L1	AC main power
4	L2	AC main power
5	L3 (3-phase)	AC main power for 3-phase power input
6	PE	Protective earth

Mating connector options	Degson 2EDGKDM-5.08-6P-14 Phoenix Contact 1942523 Würth Elektronik 691359740006
Pitch	5.08 mm
Wiring	14 AWG, insulation rated for 600 V

## Installation



### Mains connections

Connect L1, L2 and L3 for main bus power.

If the main voltage is from a single-phase source, connect line and neutral to L1 and L2.

If the main voltage is from a three-phase source, connect the phase to L1, L2 and L3.

Connect line and neutral to L1C and L2C for logic power.



### Warning - Hot plugging is not supported!

Plug or unplug the power connector only when power is off and after the bus LED has turned off (red LED visible at the side of the product). Plugging the power connector when power is on may cause power surges through connected devices and possibly damage them.

## 3.4.2 Interface X14: I/O and Brake Power

Connector X14 allows the user to provide a DC power supply to the isolated I/Os and motor brake. Typically, the isolated I/Os use 24 VDC. The I/O power is internally connected to each I/O port to allow users to tap this power supply easily within the same connector.

The brake power support up to 48 VDC. This power is internally connected to the brake output port.

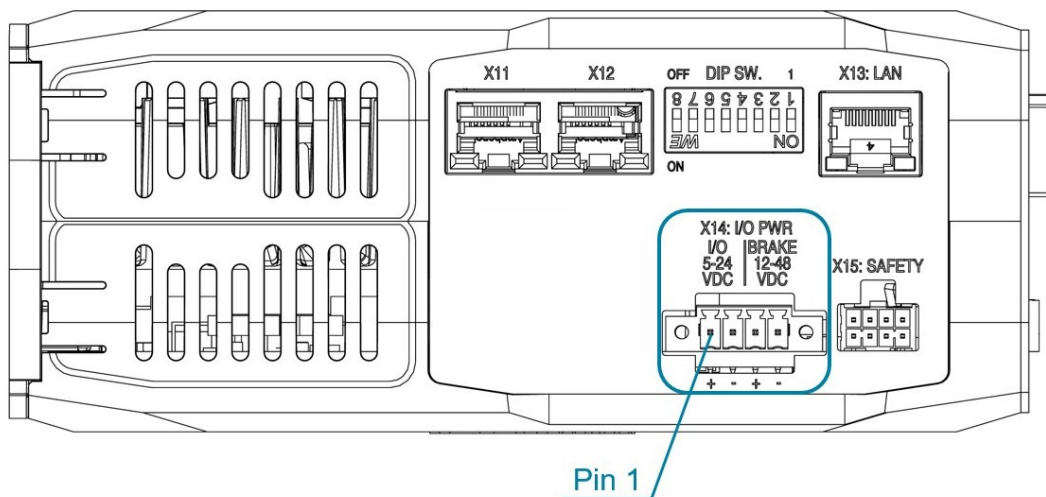

Figure 10. I/O and Brake Power Connector

### Connector X14: I/O PWR

Pin #	Name	Description
1	I/O Power	5 to 24 VDC – User supplied I/O power input, up to 2A
2	I/O Power Return	Ground – I/O power return
3	VBrake	12 to 48 VDC – Brake power input, up to 70W
4	VBrake Return	Ground – Brake power return

Mating connector options	Degson	15EDGKDM-3.5-04P-1
	Phoenix Contact	1966114
	Würth Elektronik	691364100004
Pitch	3.5 mm	
Wiring	AWG 18, insulation rated for 100 V	

## Installation



**Warning - Hot plugging is forbidden!**

Plug or unplug the power connector only when power is off! Plugging the power connector when power is on may cause power surges through connected devices and possibly damage them.

### 3.4.3 Interface X7: Motor

Connector X7 supplies power to the motor, which can be a 3-phase brushless motor, or a 1-phase brushed motor or voice coil motor.

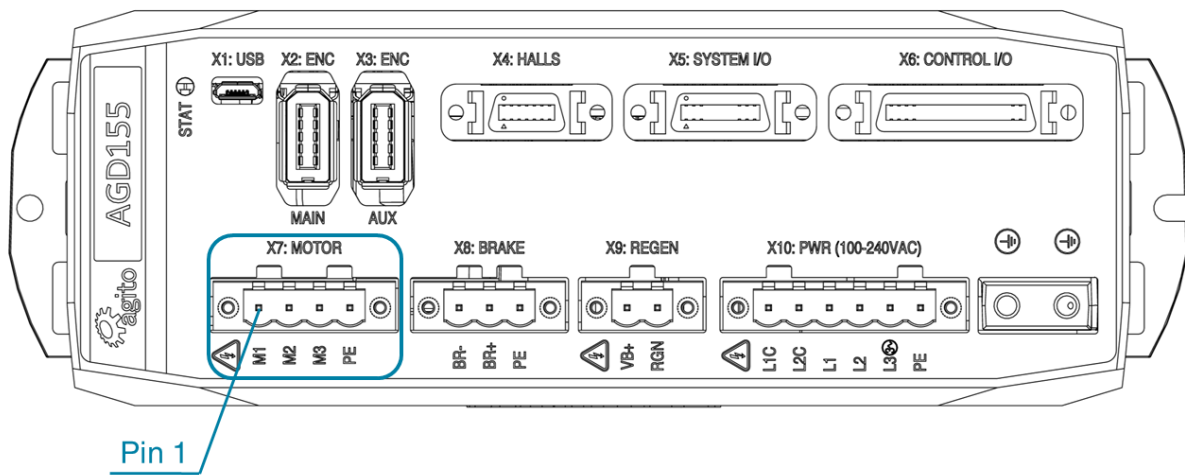

Figure 11. Motor Connector

#### For Brushless Motor

##### Connector X7: MOTOR (Brushless Motor)

Pin #	Name	Description
1	Phase A	Motor phase A (M1)
2	Phase B	Motor phase B (M2)
3	Phase C	Motor phase C (M3)
4	PE	Protective earth (motor power cable shield)

Mating connector options	Degson 2EDGKDM-5.08-4P-14 Phoenix Contact 1942507 Würth Elektronik 691340500004
Pitch	5.08 mm
Wiring	14-16 AWG, insulation rated for 600 V

#### For Brush (or Voice Coil) Motor

##### Connector X7: MOTOR (Brushed or Voice Coil Motor)

Pin #	Name	Description
1	Motor Phase +	Positive terminal, phase A or M1

## Installation

Pin #	Name	Description
2	Motor Phase -	Negative terminal, phase B or M2
3	NC	Do not connect
4	PE	Protective earth (motor power cable shield)

Mating connector options	Degson 2EDGKDM-5.08-4P-14 Phoenix Contact 1942507 Würth Elektronik 691340500004
Pitch	5.08 mm
Wiring	14-16 AWG, insulation rated for 600 V

### 3.4.4 Interface X15: Safety

Connector X3 is used for the hardware safety function that disables power to the motor.

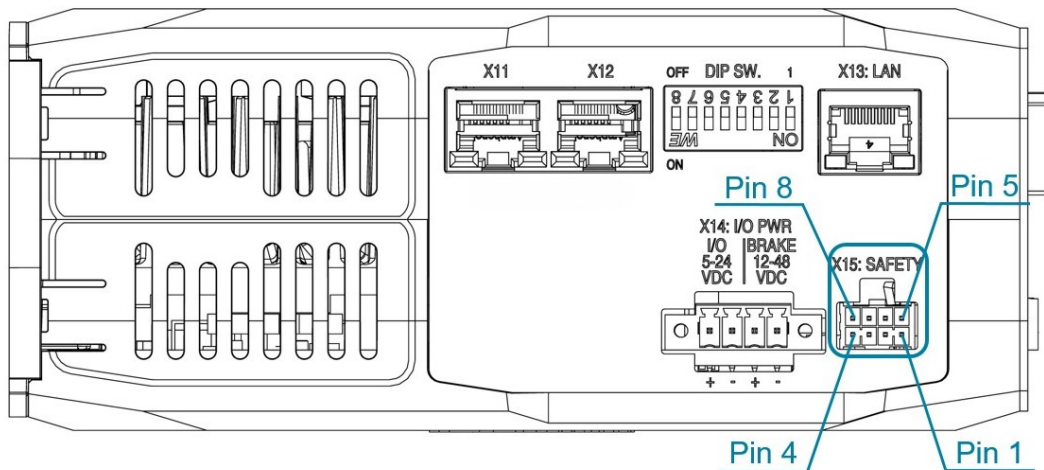

Figure 12. Safety Connector

#### Connector X15: SAFETY

Pin #	Name	Description
1	5V	5V supply for safety circuits
2	Feedback -	Safety feedback negative (emitter) output
3	Safety 2 -	Safety Input 2 negative input
4	Safety 1 -	Safety Input 1 negative input
5	GND	GND
6	Feedback +	Safety feedback positive (collector) output
7	Safety 2 +	Safety Input 2 positive input
8	Safety 1 +	Safety Input 1 positive input

Mating connector options	Samtec IPD1-04-D-K
Crimp	Samtec CC79L-2630-01-L
Wiring	26 AWG, insulation rated for 100 V

- The safety circuit consists of two input channels, labeled Safety 1 and Safety 2. Both input channels support a voltage range of 5 VDC to 24 VDC. It is recommended to use 24 VDC for the input voltage as it provides better electromagnetic interference (EMI) immunity.
- Safety 1 and Safety 2 function independently, thus providing safety redundancy. Each one can disable the power to the motor.
- Both Safety 1 and Safety 2 disable the power to the motor through hardware connection, without any software intervention.
- Both Safety 1 and Safety 2 are defined with a positive pin (+) and a negative pin (-). However, the opto-coupler at the Safety Input has two input diodes, which enable operation at "positive" or "negative" input voltage. The input is activated when current is sufficient at one of the input diodes, regardless of the current direction. This enables NPN or PNP connection to the safety inputs.
- The Safety Input protection logic is designed so that both Safety Inputs must be powered to enable motor operation. Leaving a Safety Input disconnected prevents motor operation. This logic is required to ensure that a disconnected safety cable is considered an unsafe condition by the control unit. When sufficient current is driven through a Safety Input, the state of this input is **Safe**. When insufficient current is driven through a Safety Input, the state of this input is **Unsafe**.
- The two Safety Inputs must be in the Safe state to enable motor operation.
- Both Safety 1 and Safety 2, although acting on the drive hardware directly, are also monitored by the controller software. The controller software generates a feedback signal to the user (Safety Feedback), which is also an isolated signal. This feedback is generated by the software and is activated if at least one of Safety 1 or Safety 2 signals is in the Unsafe state.
- The electrical characteristics of Safety 1 and Safety 2 are identical to those of all other isolated digital inputs of the controller.
- The safety inputs implemented in the product are currently pending certification Functional Safety Standards.



### Disabling Safety function

---

If the Safety function is not required in your application, you can disable it by using a bypass plug from Agito. Part number: C-AGD301-SFT

### Safety Connection Diagram Example

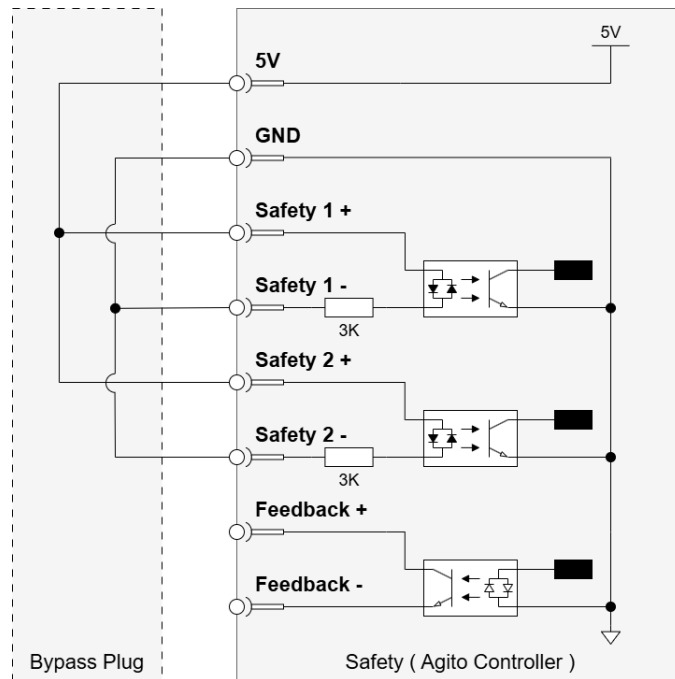

Figure 13. Safety Bypass

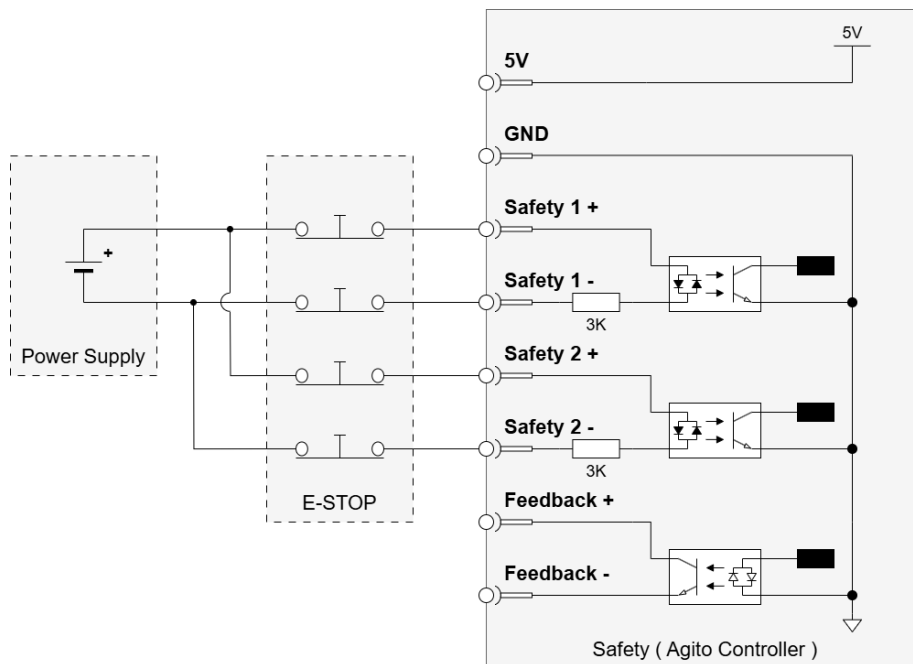

Figure 14. Safety with E-STOP

## Installation

### 3.4.5 Interface X8: Static Brake

Some motors come with a static brake, which is engaged when the motor is not enabled. Connector X8 provides the interface to connect this static brake.

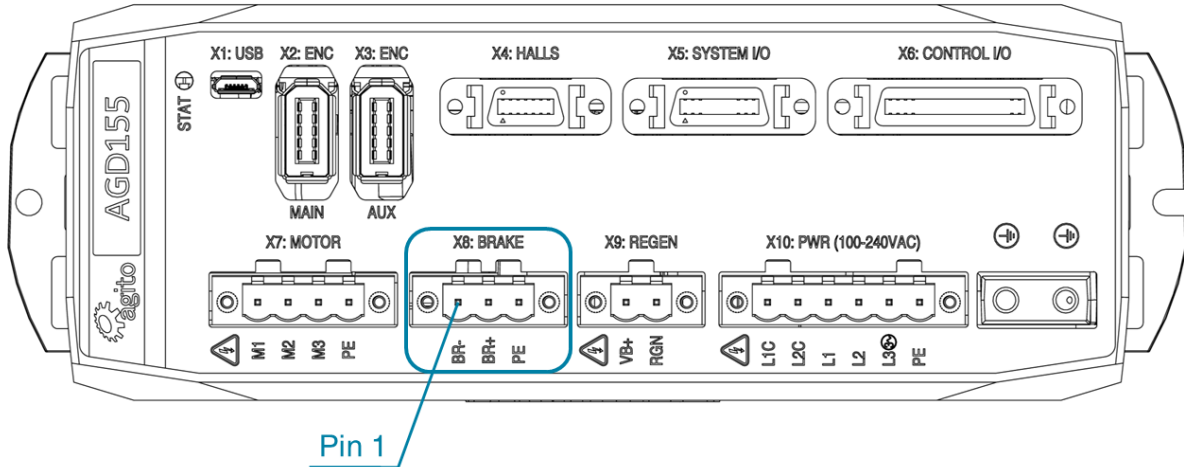

Figure 15. Brake Connector

#### Connector X8: BRAKE

Pin #	Name	Description
1	Brake -	Static brake output for motor A. Open-drain output with built-in flyback diode to the VBrake for direct connection into inductive load.
2	Brake +	Power out to brake. Internally connected to X14: I/O PWR Pin-3, VBrake.
3	PE	Protective earth

Mating connector options	Degson 2EDGKDM-5.08-3P-14 Phoenix Contact 1942497 Würth Elektronik 691340500003
Pitch	5.08 mm
Wiring	18-20 AWG, insulation rated for 100 V

#### Brake Connection Diagram Example

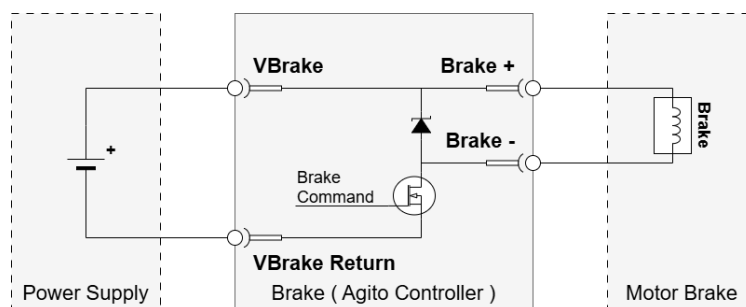

Figure 16. Brake

## Installation

### 3.4.6 Interface X9: Regeneration

Connector X9 is used to connect an external power resistor to dissipate energy generated by the motor, typically during deceleration. The motor-generated energy will charge up the internal capacitor. When the internal capacitor is fully charged, the bus voltage will increase. When bus voltage is higher than the operating limit of the product, it will trigger over-voltage protection and disable the motor. To prevent this from happening, users can connect an external power resistor to dissipate the unwanted energy.

Refer to the section *Regeneration* for more information.

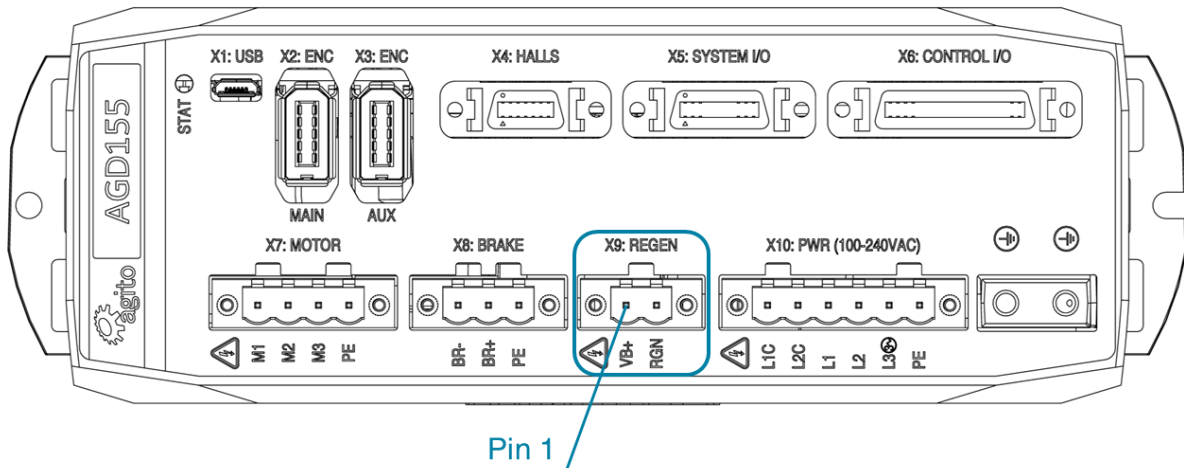

Figure 17. Regeneration Connector

#### Connector X9: REGEN

Pin #	Name	Description
1	VB+	The internal DC bus power. (Warning: This is typically more than 300 VDC)
2	Regeneration	Regeneration pin to be connected to an external regeneration resistor. Designed for 16A (not protected). When Regeneration is triggered, this pin is connected internally to PGND. The other end of the external regeneration resistor should be connected to VB+, the Internal DC Bus power (pin 1).

Mating connector options	Degson 2EDGKDM-5.08-2P-14 Phoenix Contact 1942484 Würth Elektronik 691340500002
Pitch	5.08 mm
Wiring	14-16 AWG, insulation rated for 600 V

## Installation

### 3.4.7 DIP Switches

The AGD155 includes 8 DIP switches to define CAN or Ethernet address offset, to connect a 120Ω CAN terminator resistor, to activate firmware download mode, and set other functions. These are hardware configurations that are typically done only once, during product installation.

The value of the DIP switches, as read by the controller during power on (or reset), can be queried using ADebugData[4] in Agito PCSuite terminal.

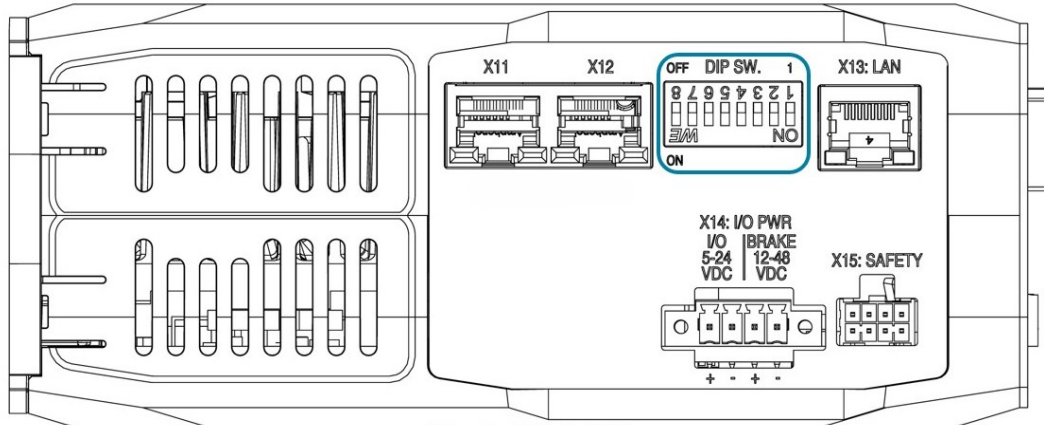

Figure 18. DIP Switches

#### DIP Switches

DIP Switch #	Function	Description
1	CAN Bus Terminator	Set to ON to connect 120Ω terminator resistor. Only the last unit in the CAN network needs to have this set to ON.
2	Force Download Firmware	Set to ON and power cycle to force the product into firmware download mode. Otherwise, always keep in OFF state.
3	Force Communication to Default	Forces the controller to default communication parameters (bypassing other software parameters in the controller): Ethernet IP: 172.1.1.101 Ethernet Port: 50000 CAN Address: 64 CAN and RS232/USB baud rates are not affected by this DIP switch. Requires power cycle or reset.
4-6	CAN/Ethernet Address Offset DIP Switch 4 – Most significant bit DIP Switch 6 – Least significant bit	DIP switches 4-5-6 create a three-bit value. For example, if DIP switch 4 is set to ON (value of 1), and 5 and 6 are set to OFF (value of 0), the result is: 100 (binary), meaning a value of 4. This value (referred to as <i>offset</i> ) is used to define the drive's CAN bus address and Ethernet IP address as follows: <b>Ethernet IP:</b> the actual fourth number of the IP address is equal to: EthernetIP [4] + <i>offset</i> <b>CAN address:</b> the actual CAN address of the unit is equal to: CANAddr + <i>offset</i> * 16 Note: Requires power cycle or reset.
7	Reserved for Future Use	Always keep at OFF state.

DIP Switch #	Function	Description
8	Reserved for Future Use	Always keep at OFF state.

### 3.4.8 Interface X13: Ethernet (LAN)

Connector X13 is an Ethernet communication port.

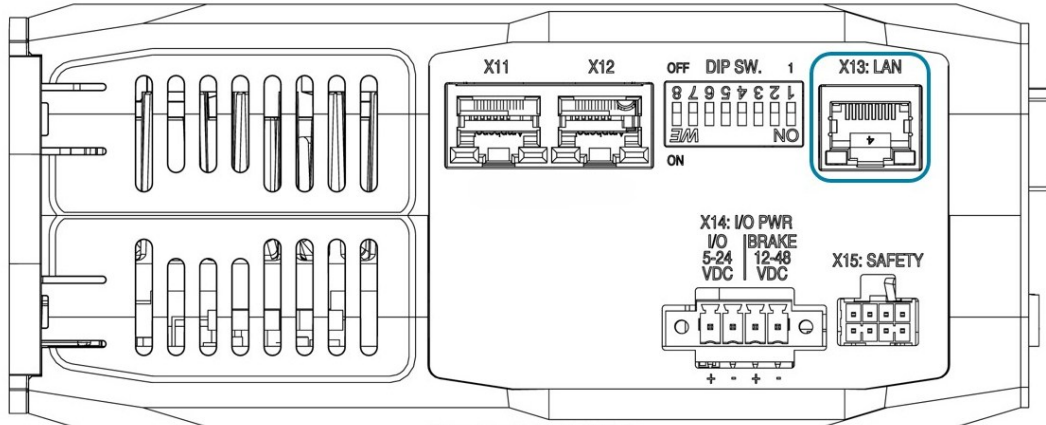

Figure 19. Ethernet Connector

#### Connector X13: LAN (Ethernet)

Pin #	Name	Description
1	TX+_D1	Transmit data +
2	TX-_D1	Transmit data -
3	RX+_D2	Receive data +
4	BI+_D3	Bi-directional +
5	BI-_D3	Bi-directional -
6	RX-_D2	Receive data -
7	BI+_D4	Bi-directional +
8	BI-_D4	Bi-directional -

Connector type	RJ45 LAN 10/100Base-T connector
Mating connector options	Any CAT5e compatible shielded connector
Cable	CAT5e or higher, standard Ethernet straight cable
Wiring	26 AWG, insulation rated for 100 V

### 3.4.9 Interfaces X11, X12 – Fieldbus

On the AGD155-EC, connectors X11 and X12 are EtherCAT communication ports.

On the AGD155-AF, connectors X11 and X12 are serial RJ45 communication ports.

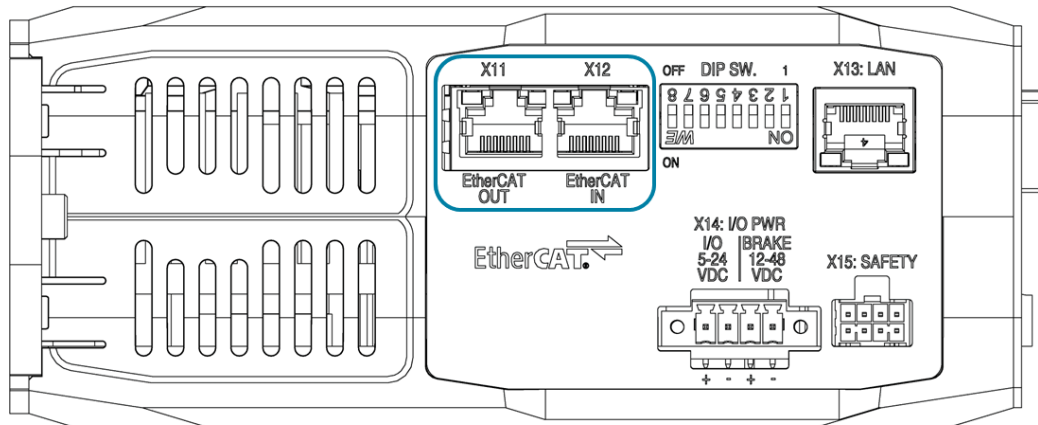

Figure 20. EtherCAT Connectors (AGD155-EC)

#### Connectors X11 and X12: EtherCAT IN and EtherCAT OUT

Pin #	Name	Description
1	TX +	Transmit data +
2	TX -	Transmit data -
3	RX +	Receive data +
4	–	–
5	–	–
6	RX -	Receive data -
7	–	–
8	–	–

Connector type	RJ45 LAN 10/100Base-T connector
Mating connector options	Any CAT5e compatible shielded connector
Cable	CAT5e or higher, standard Ethernet straight cable
Wiring	26 AWG, insulation rated for 100 V

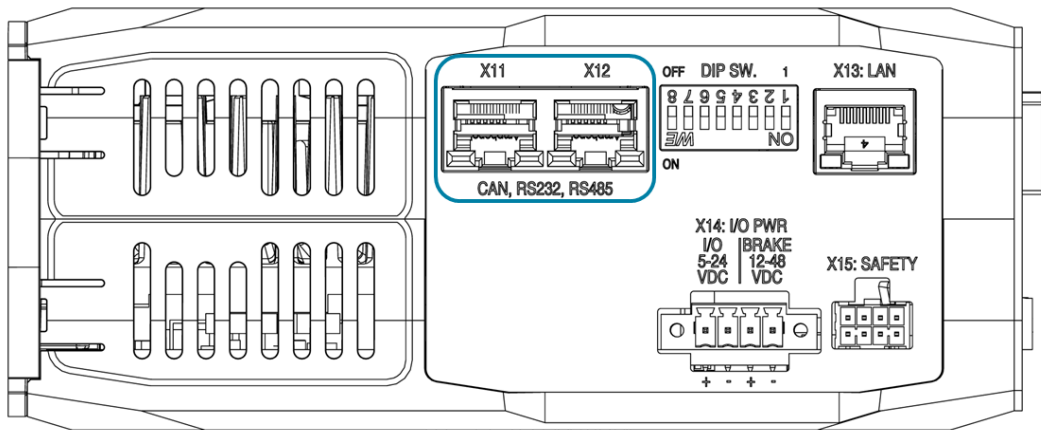

Figure 21. Serial Communication Connectors (AGD155-AF)

### Connectors X11 and X12: CAN, RS232, RS485

Pin #	Name	Description
1	GND	Digital Ground
2	RS232_RX	RS232 input (receive at product)
3	RS232_TX	RS232 output (transmit from product)
4	RS485_B	RS485 bus, inverted
5	RS485_A	RS485 bus, not inverted
6	SYNC	Reserved for future use
7	CAN_L	CAN bus, Low
8	CAN_H	CAN bus, High

Connector type	RJ45 LAN 10/100Base-T connector
Mating connector options	Any CAT5e compatible shielded connector
Cable	CAT5e or higher, standard Ethernet straight cable
Wiring	26 AWG, insulation rated for 100 V



#### Dual port connector

The serial port is a dual-port RJ45 connector. The two ports have identical pinouts and are interchangeable. Two ports are provided to support daisy chain connection of a CAN bus or RS485. It can be also used to connect two types of communication channels at the same time, instead of splitting a cable from a single RJ45 connector.



#### CAN bus and RS485 terminators

The CAN bus lines have an optional 120Ω terminator that is connected/disconnected by DIP switch #1 in the DIP SW interface (on the top panel). Setting dip switch #1 to the ON position connects a 120Ω terminator between CAN\_H and CAN\_L. The terminator is required only in the last unit in the CAN bus chain.

The RS485 lines have a built-in (not optional) 120Ω terminator. Communication performance may be degraded if too many units are placed on the RS485 chain.

### 3.4.10 Interface X1: Micro USB

Connector X1 is a Micro-USB communication port.

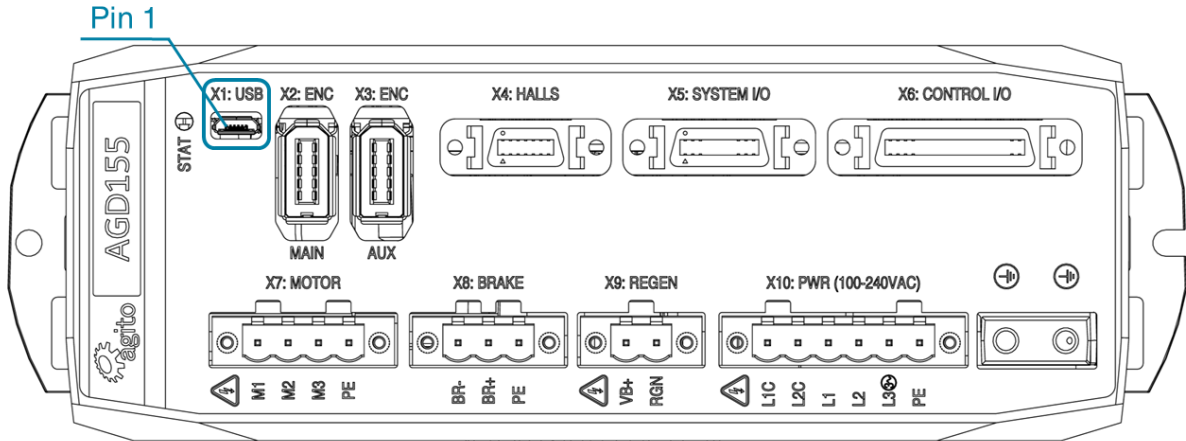

Figure 22. USB Connector

#### Connector X1: Micro USB

Pin #	Name	Description
1	VCC	5V
2	D-	Data-
3	D+	Data+
4	ID	USB OTG ID
5	GND	GND

Connector type	Micro-USB 2.0 B
Cable	Any Micro-USB 2.0 B-type cable
Wiring	20 to 28 AWG, insulation rated for 100 V



#### USB to RS232 bridge

The Micro-USB connection is implemented using an internal converter/adapter from USB to RS232 (UART). Typically, the Windows OS contains a built-in driver for the convertor/adapter. If necessary, you can access drivers at: <http://www.ftdichip.com/Drivers/D2XX.htm>.

## Installation

### 3.4.11 Interface X2: Main Encoder

The X2 encoder port is designed to interface with the main (primary position feedback) encoder for the axis.

This port supports digital quadrature incremental encoders (AqB), analog sin/cos incremental encoders, absolute BiSS-C encoders, and absolute EnDat2.2 encoders. The type of encoder connected to the AGD155 is configured in the Agito PCSuite software.

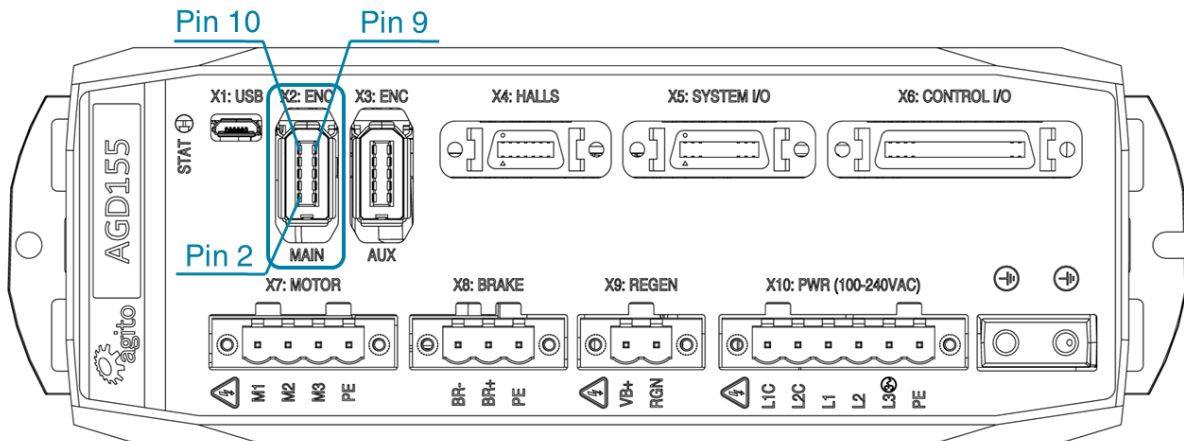

Figure 23. Main Encoder Connector

#### Connector X2: ENC (MAIN)

Pin #	Name	Encoder Types				Description
		AqB	Sin/Cos	BiSS-C	EnDat 2.2	
1	5V					5V power supply (limited to 0.5A per connector)
2	GND					5V return and reference for differential signals
3	Encoder_1+			CLOCK+	CLOCK+	Clock+ pin for absolute encoders
4	Encoder_1-			CLOCK-	CLOCK-	Clock- pin for absolute encoders
5	Encoder_2+	A+	SIN+			A+ (for AqB) or sin+ (for analog sin/cos)
6	Encoder_2-	A-	SIN-			A- (for AqB) or sin- (for analog sin/cos)
7	Encoder_3+	B+	COS+			B+ (for AqB) or cos+ (for analog sin/cos)
8	Encoder_3-	B-	COS-			B- (for AqB) or cos- (for analog sin/cos)
9	Encoder_4+	Z+	Z+	DATA+	DATA+	Data+ for absolute encoders, or Z+ for both AqB and analog sin/cos encoder
10	Encoder_4-	Z-	Z-	DATA-	DATA-	Data- for absolute encoders, or Z- for both AqB and analog sin/cos encoder

Mating connector options	Sunchu SC-10-4P 3M 36210-0100PL + 36310-3200-008
Wiring	AWG 26, insulation rated for 100 V

## Installation



### Note – Incremental encoder interface details

By default, the product does not support single-ended encoder. For use of single-ended encoder, contact Technical Support.



### Note – 5V supply limitation

The maximum current available for the encoder is 0.5 A.

## 3.4.12 Interface X3: Auxiliary Encoder

The X3 encoder port is designed to interface with an auxiliary (second) encoder for the axis.

This port is similar to the main encoder port, supporting digital quadrature incremental encoder, absolute BiSS-C and absolute EnDat2.2 encoder. However, it does not support analog sin/cos encoder input.

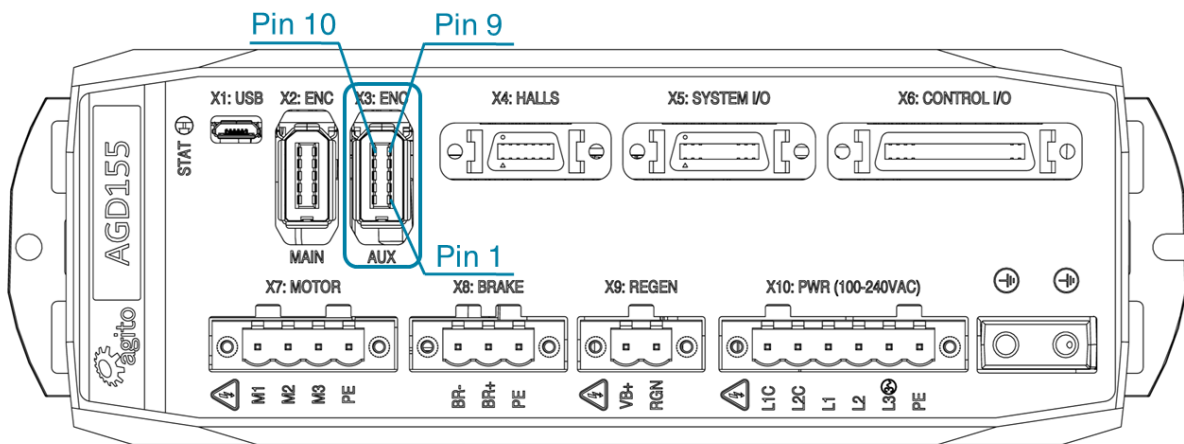

Figure 24. Aux Encoder Connector

### Connector X3: ENC (AUX)

Pin #	Name	Encoder Types			Description
		AqB	BiSS-C	EnDat 2.2	
1	5V				5V power supply (limited to 0.5A per connector)
2	GND				5V return and reference for differential signals
3	Encoder_1+		CLOCK+	CLOCK+	Clock+ pin for absolute encoders
4	Encoder_1-		CLOCK-	CLOCK-	Clock- pin for absolute encoders
5	Encoder_2+	A+			A+ (for AqB)
6	Encoder_2-	A-			A- (for AqB)
7	Encoder_3+	B+			B+ (for AqB)
8	Encoder_3-	B-			B- (for AqB)
9	Encoder_4+	Z+	DATA+	DATA+	Data+ for absolute encoders, or Z+ for AqB
10	Encoder_4-	Z-	DATA-	DATA-	Data- for absolute encoders, or Z- for AqB

Mating connector options	Sunchu 3M	SC-10-4P 36210-0100PL + 36310-3200-008
--------------------------	-----------	---

## Installation

Wiring	AWG 26, insulation rated for 100 V
--------	------------------------------------



### Incremental encoder interface details

---

By default, the product does not support single-ended encoder. For use of single-ended encoder, contact Technical Support.



### Note – 5V supply limitation

---

The 5V supply provided at pin 1 of each ENC connector is internally limited to 0.5A.

### 3.4.13 Interface X4: Hall Sensor

Connector X4 provides the interface for the digital Hall effect sensors and temperature sensor from the motor.

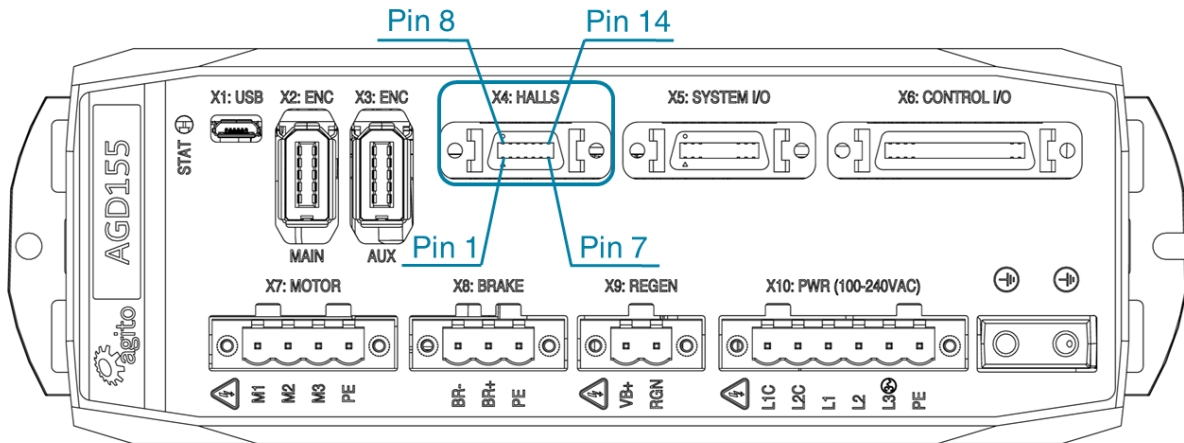

Figure 25. Hall Sensor Connector

#### Connector X4: HALLS

Pin #	Name	Software Representation	Description
1	5V		5V supply to Hall sensor. Connect to pin 10 when using digital inputs 1 to 3 for Hall sensor.
2	GND		GND for 5V.
3	PT1000_EN		AGD155-AF: Not used. AGD155-EC: For PT1000 temperature sensor, this pin is shorted to pin 6 (GND). For PT100 temperature sensor, this pin is not connected.
4	Digital Input 1 (Hall A)	DInPort.bit(0)	Isolated digital input 1 (NPN or PNP, depending on the connection of the group's common pin). To use as Hall input, go to the Agito PCSuite Digital Input page, and configure as Hall A. The following inputs (2 and 3) will be set automatically as Hall B and Hall C.
5	Digital Input 2 (Hall B)	DInPort.bit(1)	Isolated digital input 2 (NPN or PNP, depending on the connection of the group's common pin).
6	GND		AGD155-AF: Not used. AGD155-EC: Connect to GND.
7	PE		PE
8	Temp+		PT100+ /Thermostat+ (or PT1000+ if Pin 3 is shorted to pin 6 for AGD155-EC).
9	Temp-		PT100- /Thermostat- (or PT1000- if Pin 3 is shorted to pin 6 for AGD155-EC).

Pin #	Name	Software Representation	Description
10	Digital Input Common (1 to 3)		Common pin (power or return, depending on external connection) for digital input 1 to 3.
11	Digital Input 3 (Hall C)	DInPort.bit(2)	Isolated digital input 3 (NPN or PNP, depending on the connection of the group's common pin).
12	Digital Input 4	DInPort.bit(3)	Isolated digital input 4, PNP only.
13	I/O Power		Internally connected to connector X14: I/O PWR pin 1, I/O Power.
14	I/O Power Return		Internally connected to connector X14: I/O PWR pin 2, I/O Power Return.

Mating connector options	Sunchu SC-14-3 3M 10114-3000PE + 10314-52A0-008
Wiring	AWG 26, insulation rated for 100 V



**Note – 5V supply limitation**

The 5V supply provided at pin 1 is limited to 0.5A per connector. The maximum total current provided by all the 5V pins in the product is limited to 1.5A.

**Hall Sensor Connection Diagram Example**

- Motor Hall sensor can be connected to opto-isolated digital inputs 1, 2, and 3 on connector X4 (HALLS). In Agito PCSuite the first input must be configured to mode 23-Hall A.
- It is recommended that Hall sensor be used with incremental encoders. Typically, Hall sensor is called Ha Hb Hc, or Hu Hv Hw, or H1 H2 H3, which correspond to the motor phases. A typical Hall sensor is an open collector (NPN) type and requires a 5 VDC power supply.
- Motor Hall sensors are wired as standard digital inputs.

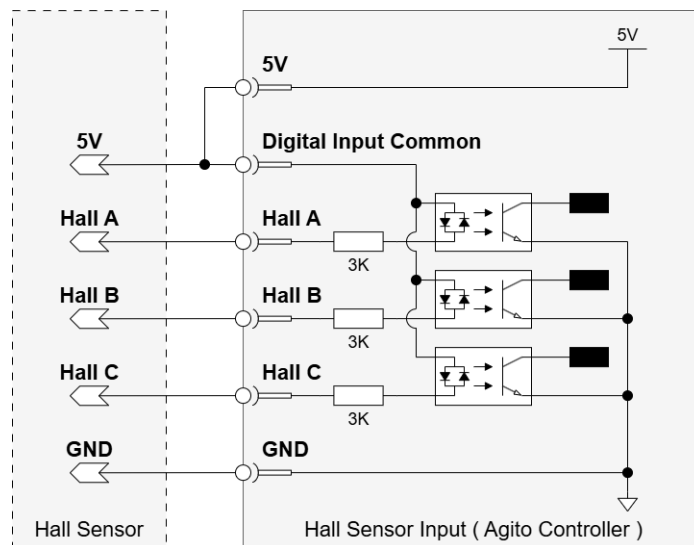

Figure 26. Hall Sensor

### 3.4.14 Interface X5: System I/Os

Connector X5 provides the interface for I/O devices, such as a limit sensor and home switch, which are typically mounted on the actuator or on the machine.

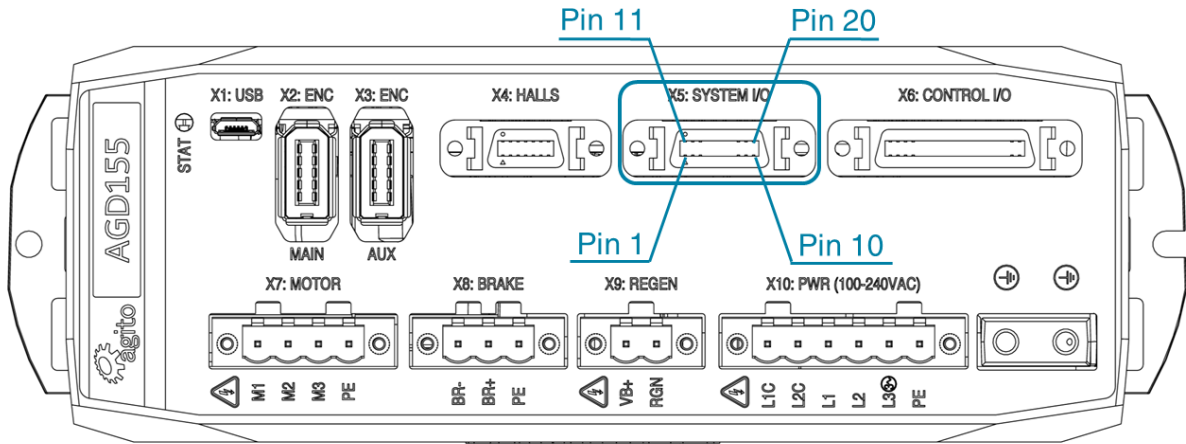

Figure 27. System I/O Connector

#### Connector X5: SYSTEM I/O

Pin #	Name	Software Representation	Description
1	Digital Input 12	DInPort.bit(11)	Isolated digital input 12 (NPN or PNP, depending on the connection of the group's common pin)
2	Digital Input 14	DInPort.bit(13)	Isolated digital input 14 (NPN or PNP, depending on the connection of the group's common pin)
3	Digital Input 16	DInPort.bit(15)	Isolated digital input 16 (NPN or PNP, depending on the connection of the group's common pin)
4	Digital Output 5	DOutPort.bit(4)	Isolated digital output 5, programmable sink or source
5	Digital Output 6	DOutPort.bit(5)	Isolated digital output 6, programmable sink or source
6	Analog Input 2	AInPort[2]	Analog input 2, $\pm 12V$ full scale
7	Analog Input Return 2		Analog input 2 return
8	Bi-Dir Diff I/O +	DInPort.bit(19) DOutPort.bit(10)	Bi-directional differential I/O + Software configurable: BiDirConfig.bit(0) = 0 for input BiDirConfig.bit(0) = 1 for output
9	Bi-Dir Diff I/O -		Bi-directional differential I/O -
10	GND		Ground

Pin #	Name	Software Representation	Description
11	Digital Input Common (12 to 16)		Common pin (power or return, depending on external connection) for digital inputs 12 to 16
12	Digital Input 13	DInPort.bit(12)	Isolated digital input 13 (NPN or PNP, depending on the connection of the group's common pin)
13	Digital Input 15	DInPort.bit(14)	Isolated digital input 15 (NPN or PNP, depending on the connection of the group's common pin)
14	Digital Output Common Power (5 to 6)		Common power pin for isolated digital outputs 5 to 6
15	Digital Output Common Return (5 to 6)		Common power return pin for isolated digital outputs 5 to 6
16	Analog Output 1	AoutPort[1]	Analog output 1, ±12V full scale, AGD155-AF only.
17	Analog Output 2	AoutPort[2]	Analog output 2, ±12V full scale AGD155-AF only.
18	GND		Ground
19	I/O Power		Connected internally to connector X14: I/O PWR pin 1, I/O Power
20	I/O Power Return		Connected internally to connector X14: I/O PWR pin 2, I/O Power Return

Mating connector options	Sunchu SC-20-3 3M 10120-3000PE + 10320-52A0-008
Wiring	AWG 26, insulation rated for 100 V

## Installation

### 3.4.15 Interface X6: Control I/Os

Connector X6 includes a typical set of I/Os (digital isolated, fast differential, and analog) for operation with an external controller by means of  $\pm 10V$  analog commands or digital pulse and direction commands.

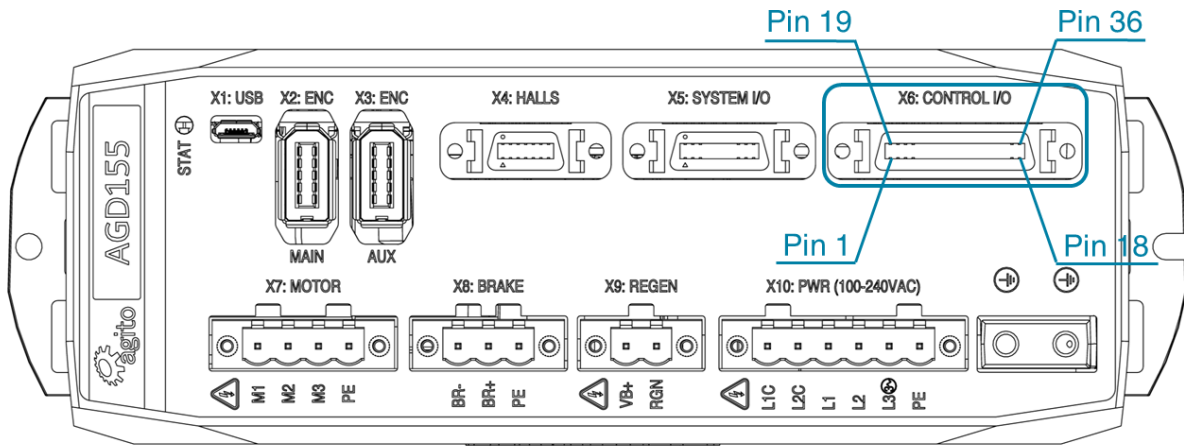

Figure 28. Control I/O Connector

#### Connector X6: CONTROL I/O

Pin #	Name	Software Representation	Description
1	Diff Output 1 +	DOutPort.bit(6)	Differential output 1+   Emulated encoder A+
2	Diff Output 1 -		Differential output 1-   Emulated encoder A-
3	Diff Output 3 +	DOutPort.bit(8)	Differential output 3+   Emulated encoder Z+
4	Diff Output 3 -		Differential output 3-   Emulated encoder Z-
5	GND		GND for the differential I/Os
6	Analog Input 1	AIInPort[1]	Analog Input 1, +/-12V full scale
7	Analog Input Return 1		Analog input 1 return
8	Diff Input 2 +	DInPort.bit(17)	Differential input 2+   Direction input+   Encoder follower B+   Handwheel B+
9	Diff Input 2 -		Differential input 2-   Direction input-   Encoder follower B-   Handwheel B-
10	GND		GND for the differential I/Os
11	Digital Input 5	DInPort.bit(4)	Isolated digital input 5 (NPN or PNP, depending on the connection of the group's common pin)
12	Digital Input 7	DInPort.bit(6)	Isolated digital input 7 (NPN or PNP, depending on the connection of the group's common pin)
13	Digital Input 9	DInPort.bit(8)	Isolated digital input 9 (NPN or PNP, depending on the connection of the group's common pin)
14	Digital Input 11	DInPort.bit(10)	Isolated digital input 11 (NPN or PNP, depending on the connection of the group's common pin)
15	Digital Output 1	DOutPort.bit(0)	Isolated digital output 1, programmable sink or source

Pin #	Name	Software Representation	Description
16	Digital Output Common Power (1 to 4)		Common power pin for isolated digital outputs 1 to 4
17	Digital Output Common Return (1 to 4)		Common power return pin for isolated digital outputs 1 to 4
18	GND		GND for the differential I/Os
19	Diff Output 2 +	DOutPort.bit(7)	Differential output 2+   Emulated encoder B+
20	Diff Output 2 -		Differential output 2-   Emulated encoder B-
21	Diff Output 4 +	DOutPort.bit(9)	Differential output 4+
22	Diff Output 4 -		Differential output 4-
23	GND		GND for the differential I/Os
24	Diff Input 1 +	DInPort.bit(16)	Differential input 1+   Pulse input+   Encoder follower A+   Handwheel A+
25	Diff Input 1 -		Differential input 1-;   Pulse input-   Encoder follower A-   Handwheel A-
26	Diff Input 3 +	DInPort.bit(18)	Differential input 3+
27	Diff Input 3 -		Differential input 3-
28	GND		GND for the differential I/Os
29	Digital Input Common (5 to 11)		Common pin (power or return, depending on external connection) for digital input 5 to 11
30	Digital Input 6	DInPort.bit(5)	Isolated digital input 6 (NPN or PNP, depending on the connection of the group's common pin)
31	Digital Input 8	DInPort.bit(7)	Isolated digital input 8 (NPN or PNP, depending on the connection of the group's common pin)
32	Digital Input 10	DInPort.bit(9)	Isolated digital input 10 (NPN or PNP, depending on the connection of the group's common pin)
33	Digital Output 2	DOutPort.bit(1)	Isolated digital output 2, programmable sink or source
34	Digital Output 3	DOutPort.bit(2)	Isolated digital output 3, programmable sink or source
35	Digital Output 4	DOutPort.bit(3)	Isolated digital output 4, programmable sink or source
36	5V		5V output

Mating connector options	Sunchu SC-36-3 3M 10136-3000PE + 10336-52A0-008
Wiring	AWG 26, insulation rated for 100 V

## Installation



### Note – 5V Digital Output Common Power source mode limitation.

When using 5V Digital Output Common Power in source mode, higher current (but less than the absolute maximum value of 250 mA) can be driven. However, the output high voltage will drop significantly. To maintain output high voltage at > 4.5V, limit the current to 60 mA.



### Note – Differential I/O connection details.

AGD155 Differential Input X- and Differential Output X- are not GND. They must be connected to the negative (-) side of a differential pair in the customer's machine electronics.

## I/O Connection Diagram Example

### Isolated Digital Inputs 1 to 3, 5 to 11, 12 to 16

- The interface circuit is identical for all 15 digital inputs, except Digital Input 4. Refer to the electrical interface of Digital Input 4.
- Digital Input Common are grouped by digital inputs 1 to 3, 5 to 11 and 12 to 16. Digital Input 4 is not a part of these groups.
- Each group is fully isolated and independent of the other groups.
- Each group can be connected as NPN or PNP interfaces, depending on the wiring of the group's Digital Input Common pin. If the Digital Input Common pin is connected to power (between 5V and 24V), then the inputs of this group can be used with external NPN devices (external current sinking devices). If the Digital Input Common is connected to the GND of an external power supply, then the inputs of this group can be used with external PNP devices (external current sourcing devices).
- The input circuit of the opto-couplers includes two diodes. This enables use as NPN or PNP.
- One group can be wired to interface external NPN devices and another group can be wired to interface PNP devices. However, within a group, all interfaces (NPN or PNP) must be the same, as they are based on the connection of the group's Digital Input Common pin.

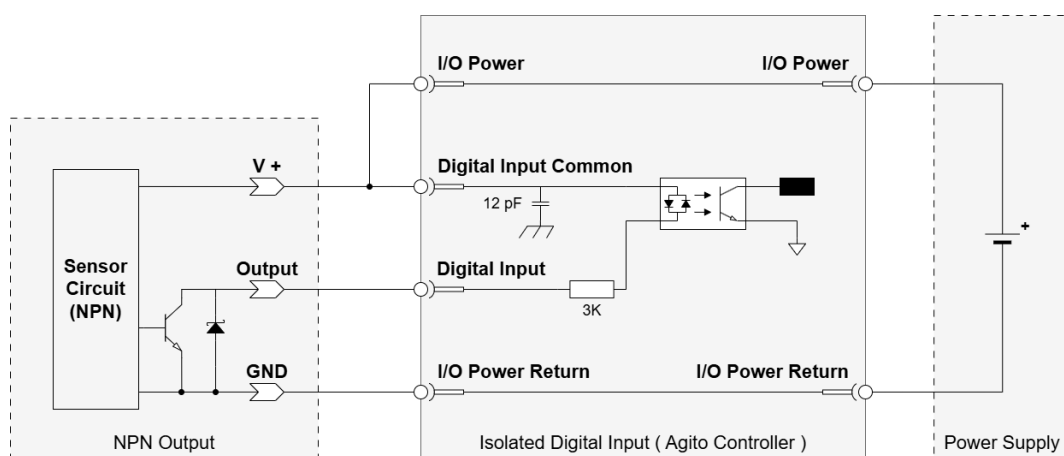

Figure 29. Digital Input with NPN Sensor

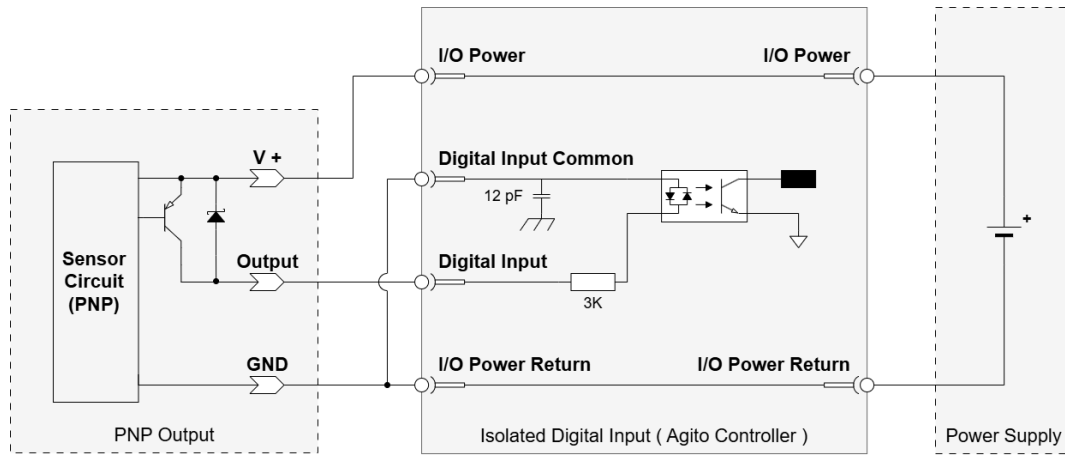

Figure 30. Digital Input with PNP Sensor

### Isolated Digital Input 4

- Digital Input Common 4 is internally pulled to I/O Power Return. It can only be connected as PNP input.

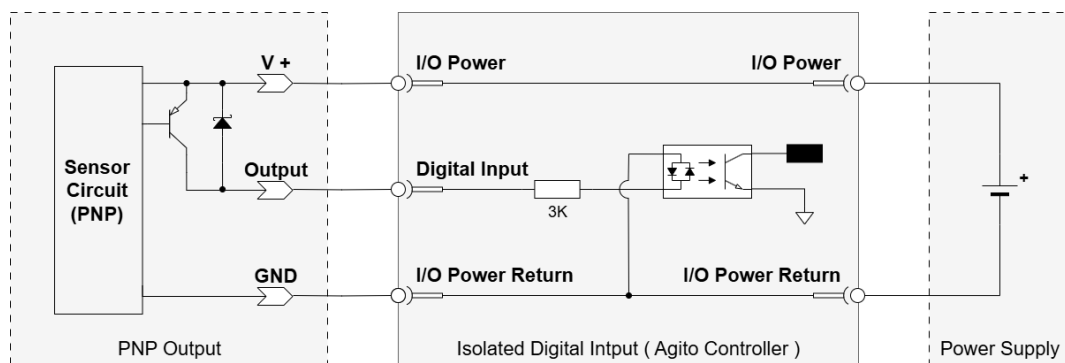

Figure 31. Digital Input 4

### Isolated Digital Outputs 1 to 4, 5 to 6

- The interface circuit is identical for all outputs.
- Each output can be programmed (by software parameter) to act as a current sourcing output (up to 300mA), or as a current sinking output (up to 500mA).
- Digital Output Common Power is organized into two groups – digital output 1 to 4, and digital output 5 to 6.
- The outputs are designed for resistive loads. For inductive loads, an external flyback diode is required.
- Digital outputs specifications:
  - Digital Output Common Power voltage range is between 5V and 28V.
  - Maximal load current, per each output:

## Installation

Sink mode, any Digital Output Common Power voltage: 500 mA  
 Source mode, at 24V Digital Output Common Power: 300 mA  
 Source mode, at 5V Digital Output Common Power: 60 mA (see Note below)



### Note – 5V Digital Output Common Power source mode limitation.

When using 5V Digital Output Common Power in source mode, higher current (but less than the absolute maximum value of 250 mA) can be driven. However, the output high voltage will drop significantly. To maintain output high voltage at > 4.5V, limit the current to 60 mA.

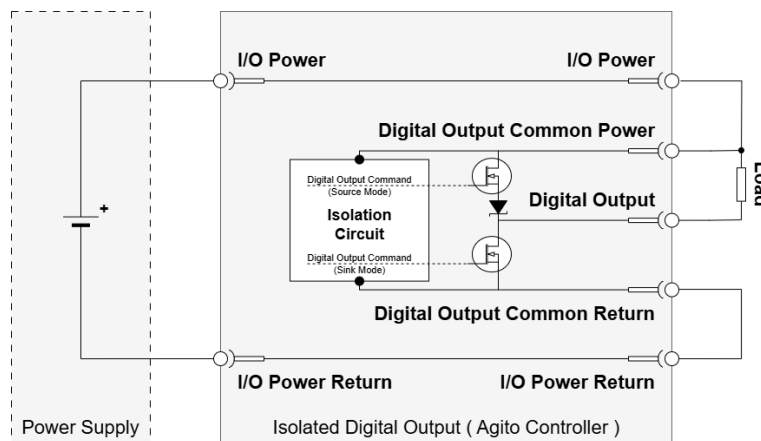

Figure 32. Digital Output (Sink Mode)

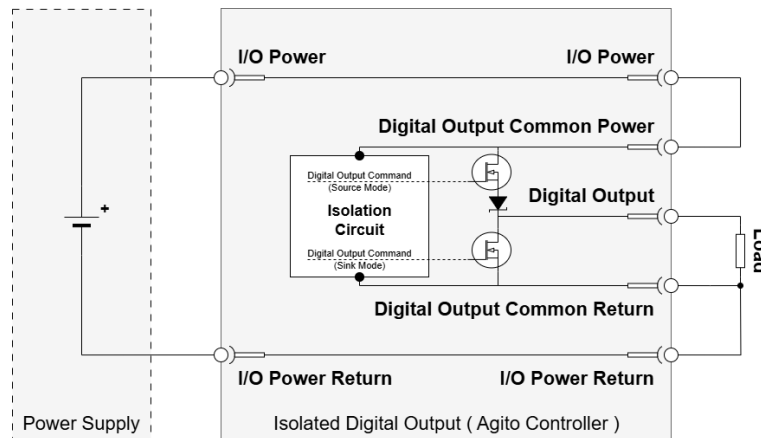

Figure 33. Digital Output (Source Mode)

## Differential Inputs 1 to 3

- Dedicated digital ground: GND (pin 10 connector X6) must be connected to GND of the controller/PLC. PE is not used for digital ground.
- Each differential input has a 120 Ω terminator.
- Each differential input has a pull-up to 3.3V on its positive pin, and a pull-down to GND on its negative pin. This ensures that the input is not floating when not connected and that its reading is known and fixed.

## Installation

- The negative input pin on each differential input also has also a pull-up to 3.3V. This enables use of a differential input with a single-ended source, by connecting it to the positive input only and leaving the negative pin disconnected.
- The max differential inputs can be used with 5V differential sources.

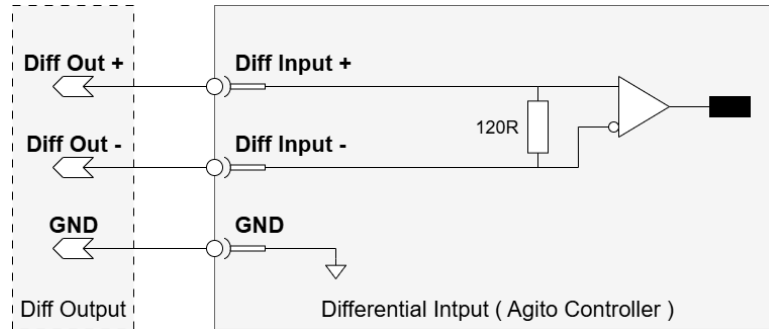

Figure 34. Differential Input

## Differential Outputs 1 to 4

- Dedicated digital ground: GND (pin 10 connector X6) shall be connected to controller/PLC GND. PE is not used for digital ground.
- The differential outputs are inactive during power on, until they are controlled by the drive firmware and the user parameters.

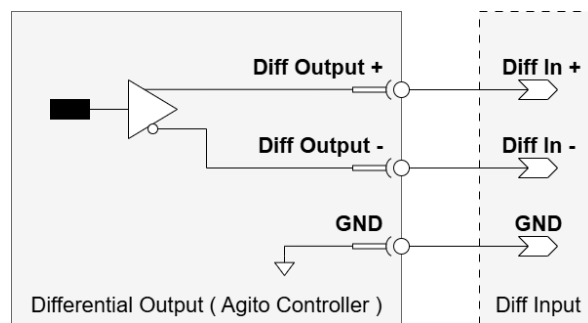

Figure 35. Differential Output

## Bi-Directional Differential I/O

- Dedicated digital ground: GND (pin 10 connector X5) must be connected to GND of the controller/PLC. PE is not used for digital ground.
- The bi-directional differential output is configurable by software to be differential output or differential input.
- Both + and - pins are pulled up to 3.3V.
- There is a 120Ω termination resistor between the + and - pins.

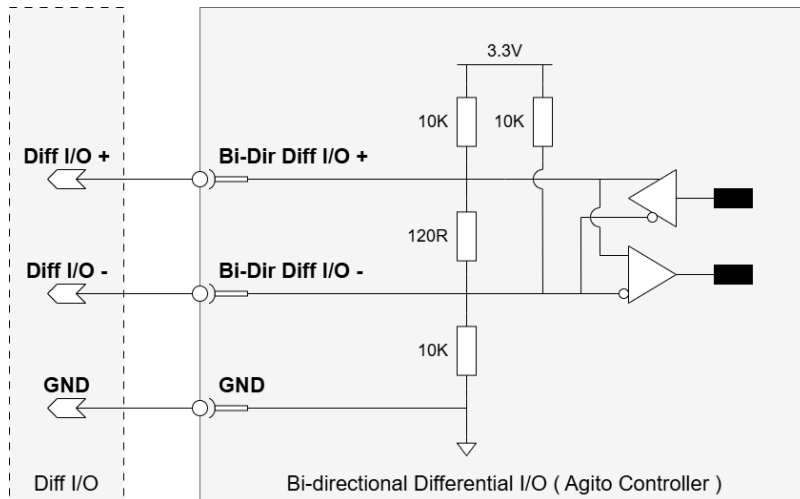

Figure 36. Bi-Directional Differential I/O

### Analog Inputs 1 to 2

- The electrical interfaces of all analog inputs are identical.
- The analog input range is -12V to +12V, and resolution is 16 bits.
- The analog input is designed for standard differential analog input, with a simple input circuit, having an input resistance of ~60 kΩ.
- For single-ended analog inputs, be sure to connect the return line to GND. Do not leave it unconnected.
- Input circuit bandwidth is 1 kHz, -40 dB/decade.
- The controller software provides the following parameters to control the analog input reading:
  - Filter
  - Offset
  - Deadband
  - Gain

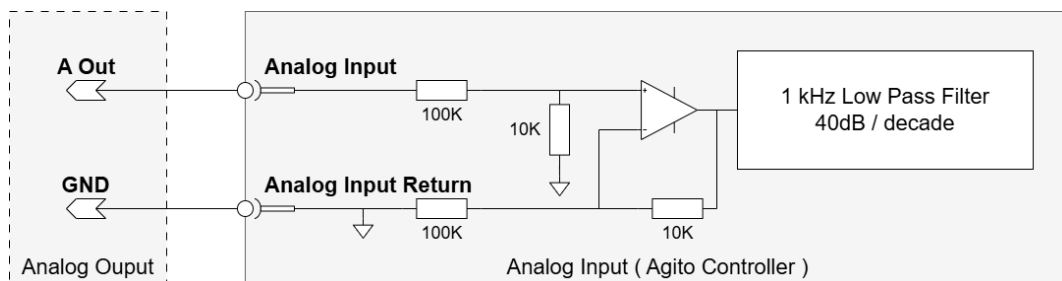

Figure 37. Analog Input

## Installation

### Analog Outputs 1 to 2

- The electrical interfaces of all analog outputs are identical.
- The analog output range is from -12V to +12V, with resolution of 16 bits.
- Output resistance is  $10\Omega$ .
- Output current is up to  $\pm 2\text{mA}$ , without internal current limitation.
- Analog outputs are controlled by the controller software in few operational modes:
  - Analog output controlled by the user program for general purpose usage.
  - Analog output reflects the internal value of a user selected parameter (position, position error, velocity, current, or any parameter/status of the controller), with a user defined scaling factor, for easy monitoring using an external oscilloscope.

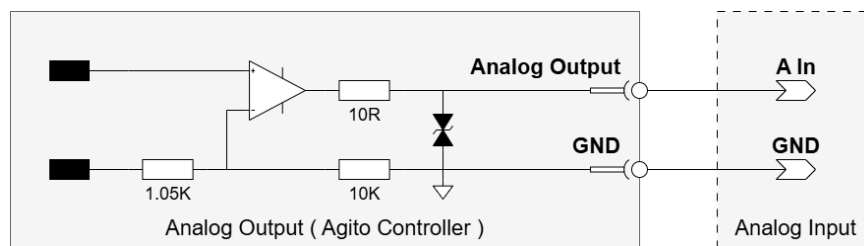

Figure 38. Analog Output

