

EtherCAT®



AGD155

Standalone 240 VAC Drive

Datasheet

Rev.3.3



www.agito-akribis.com

Member of Akribis Systems group

Product Description

The AGD155 is a 240 VAC intelligent drive with an optional EtherCAT (EoE) interface compliant with CiA 402 drive profile.

The AGD155 can drive many types of motors, such as voice coil, brushed, and brushless, including direct-drive linear and rotary motors. The drive provides numerous digital and analog inputs and outputs for application interfaces. It also supports various incremental and absolute encoders.

Advanced features include position event, position lock (capture), error mapping, dual-loop control, closed-loop force mode, and ultra-precision modes.

The AGD155 includes programming capabilities, and supports up to 8 multi-threading tasks, each of which can be configured with a different priority. It can also serve as a full-featured single-axis standalone controller.

The AGD155 also supports analog input $\pm 10V$ current or velocity commands, and pulse and direction position commands.

Agito PCSuite software is used for configuration and tuning via an Ethernet port on the drive.

Part Numbering

Product Description	Part Number Format
Standalone Drive	AGD155-xx-2Ayy[-CCC]

xx: Feature option

- **EC:** EtherCAT model
- **AF:** Standard model

yy: Continuous and peak current options

- **06:** 6 A_{rms} continuous, 18 A_{rms} peak
- **10:** 10 A_{rms} continuous, 30 A_{rms} peak

CCC: Optional customization number

Example: **AGD155-EC-2A06** indicates 6 A_{rms} continuous, 18 A_{rms} peak current

System Design Options

Note: For single-phase wiring: AC connects to L1 and L2

AGD155-EC

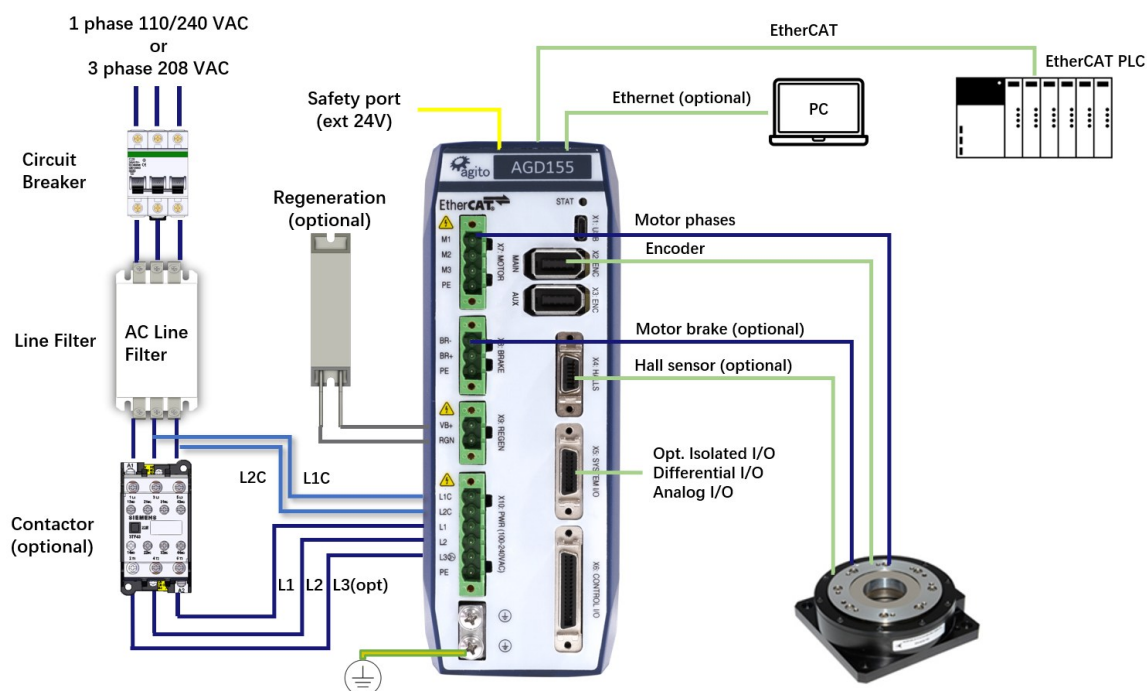

AGD155-AF

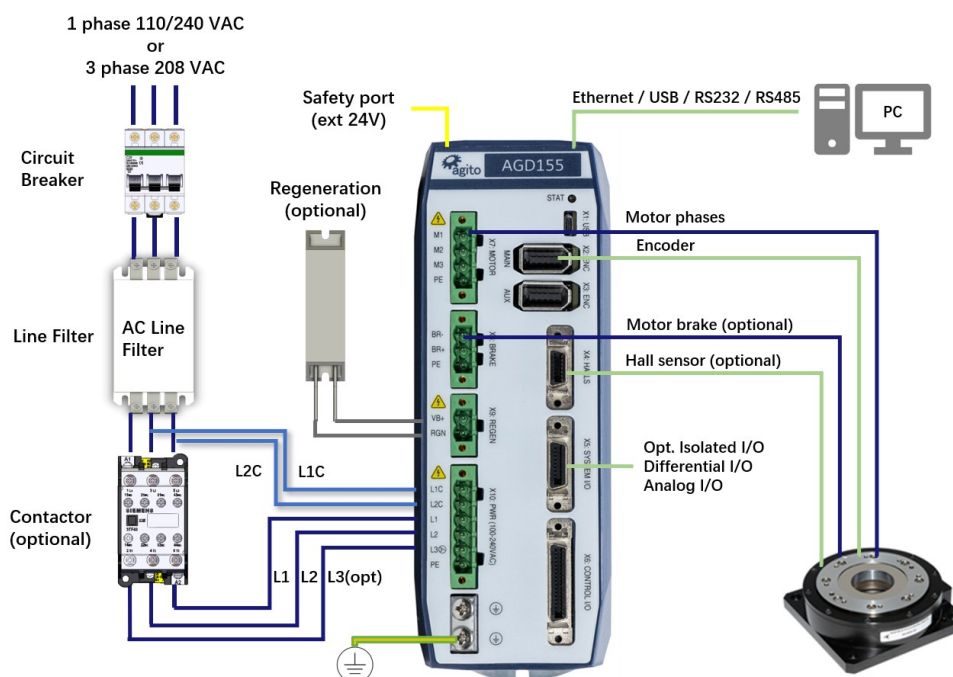

Technical Specifications

Electrical/Mechanical Specifications

Feature	AGD155-xx-2A06	AGD155-xx-2A10
Number of axes	1	
Nominal supply voltage	1-phase: 110–240 VAC L-N, 50–60 Hz 3-phase: 120 VAC L-L, 50–60 Hz	
Minimum supply voltage	1-phase: 71 VAC L-N 3-phase: 41 VAC L-L	
Maximum supply voltage	1-phase: 276 VAC L-N 3-phase, 160 VAC L-L	
Continuous output current (Internally limited by firmware)	6 A _{rms}	10 A _{rms}
Peak output current (Internally limited by firmware)	18 A _{rms}	30 A _{rms}
Output power @ 110 VAC	0.66 kVA	1.1 kVA
Output power @ 240 VAC	1.44 kVA	2.4 kVA
Input current @ 1-phase 110-240 VAC	9 A _{rms}	15 A _{rms}
Input current @ 3-phase 208 VAC	6 A _{rms}	10 A _{rms}
Peak current time	1.5 sec	
Output Frequency	0 – 599 Hz	
Short-circuit rating	Rated short-circuit breaking capacity: 5 kA*	
Isolated digital inputs	16	

Feature	AGD155-xx-2A06	AGD155-xx-2A10
Isolated digital outputs	6	
Differential inputs	3	
Differential outputs	4	
Bi-directional differential I/Os (RS422)	1	
Analog inputs	AGD155-EC: 2 (16-bit) AGD155-AF: 2 (16-bit)	
Analog outputs	AGD155-EC: NA AGD155-AF: 2	
PT100/PT1000/Thermostat inputs	1 (PT1000: AGD155-EC only)	
Brake outputs	1	
Regeneration outputs	1	
Encoder ports	2	
Hall sensor ports	1	
Motor types	Voice coil, brushed or brushless linear or rotary motor. 2-phase steppers (open and closed loop, micro-stepping)	
Communication	AGD155-EC: EtherCAT, Ethernet, USB AGD155-AF: Ethernet, USB, CAN, RS232, RS485	

Feature	AGD155-xx-2A06	AGD155-xx-2A10
PWM Frequency	16 kHz	
Power supply to external devices	Voltage: 5V Overall max. current: 1.5A	
Maximum leakage current	6 mA	
AC logic power inrush current	Max current: 2A Max duration: 1 ms	
AC main power inrush current	Max current: 7.8A Max duration: 20 ms Note: controlled by soft start	

* During compliance testing, short-circuit current was 200A

Encoder Ports Specifications

Feature	Specification
Encoder types	Incremental AqB, Sin/Cos Absolute: EnDat 2.2, BiSS-C
Power supply to encoder	0.5 A per encoder port
Max. cable length	40 m
Incremental encoder	Hardware: Differential RS422/RS485 Max. input frequency: 6.25 MHz Termination: 120 Ω Commutation: Auto-phasing, Hall sensors
Sin/Cos encoder (available on Main Encoder port only)	Hardware: Differential RS422/RS485, 1V pkp @2.5V Max. input frequency: 250 kHz Termination: 120 Ω Max interpolation: 13 bits (x 8192) Commutation: Auto-phasing, Hall sensors
Absolute BiSS-C	Hardware: Differential RS422/RS485, clock (MA), data (SLO) Clock frequency: 1 MHz Max. position bits: 32 bits Commutation: Auto-phasing, by absolute offset
Absolute EnDat 2.2	Hardware: Differential RS422/RS485, clock, data Clock frequency: 1 MHz Max. position bits: 32 bits Commutation: Auto-phasing, by absolute offset
Hall sensors	Opto-isolated 5V with internal or external power supply

I/O Specifications

Feature	Specification
Power supply for optically isolated I/Os	Voltage: 5–28 VDC
Optically isolated digital inputs	Type: PNP/NPN Propagation delay: 10 μs Max. frequency: 100 kHz Functionality: limit switches, home, captures, start motion, gain scheduling, and others
Optically isolated digital outputs	Type: Sink/Source Max current: 0.5A (for sink type), 0.3A (for source type) Propagation delay: 10 μs Max. frequency: 100 kHz Functionality: alarm, in-position, event (PEG), and others
Differential inputs	Hardware: Differential RS422 Termination: 120 Ω Propagation delay: 100 ns Max. frequency: 5 MHz Functionality: Position lock (capture), pulse and direction, AqB encoder following, Handwheel
Differential outputs	Hardware: Differential RS422 Termination: NA Propagation delay: 100 ns Max. frequency: 5 MHz Functionality: Position event, encoder emulation, alarm, statuses, and others. Differential output voltage: 3.3 VDC
Bi-directional differential I/O	Hardware: Differential RS422 Termination: 120 Ω Propagation delay: 100 ns Max. frequency: 5 MHz Direction: Input or output, set by Agito PCSuite Functionality: Any differential input or output functionality. Bi-dir differential output voltage: 2.3 VDC
Analog inputs	Operational voltage: ±12V Resolution: 16 bits
Analog outputs	Operational voltage: ±12V Resolution: 16 bits
Safety inputs	2 independent inputs Voltage: 5–28 VDC
Static brake output	Operational voltage: 24V Maximum current: 3A

