



EtherCAT®

AGD155

Standalone 240 VAC Drive

Product Manual



www.agito-akribis.com

Member of Akribis Systems group

Revision History

Version	Description	Date
3.2	Updated analog inputs and outputs	6 Dec 2023
3.1	Updated voltage specifications. Updated connector information for electrical interfaces. Added logic and bus power inrush current specifications. Added safety inputs specifications and updated Safety Circuitry. Added EtherCAT logo on cover. Various, minor text corrections.	6 June 2023
3.0	Added AGD155-EC (EtherCAT) model. Updated diagrams, improved quality of drawings and pinout diagrams. Updated X5 connector. Added analog outputs. Various, minor text corrections. Added some connector descriptions.	31 October 2022
2.3	Updated X4: Added Hall sensor circuitry. Updated X5: System I/Os connector pinout. Various, minor text corrections.	21 October 2021
2.2	Updated format for consistency with other product manuals.	18 August 2021
2.1	Updated for CE compliance. Product description revised: Standalone 240 VAC Drive. Minor text corrections.	9 June 2021
2.0	Revision of manual content and format	3 May 2021
1.0	Initial release	3 August 2020

Contact Information

Manufacturer Agito Akribis Systems Ltd., Member of Akribis Systems Group
Address 6 Yad-Harutsim St., P.O.Box 7172, Kfar-Saba 4464103
Email agito.info@akribis-sys.com
Website www.agito-akribis.com

Copyright Notice

©2023 Agito Akribis Systems Ltd.

All rights reserved. This work may not be edited in any form or by any means without written permission of Agito Akribis Systems Ltd.

Products Rights

AGDx, AGCx, AGMx, AGAx, AGIOx, and AGLx are products designed by Agito Akribis Systems Ltd. in Israel. Sales of the products are licensed to Akribis Systems Pte Ltd. under intercompany license agreement.

Agito Akribis Systems Ltd. has full rights to distribute above products worldwide.

Disclaimer

This product documentation was accurate and reliable at the time of its release.

Agito Akribis Systems Ltd. reserves the right to change the specifications of the product described in this manual without notice at any time.

Trademarks

Agito PCSuite is a trademark of Agito Akribis Systems Ltd..



Warranty

This product is warranted to be free of defects in material and workmanship and conforms to the specifications listed in this manual, for a period of 12 months from the shipment date from factory.

Contents

1	Product Description	6
1.1	General Description	6
1.2	Part Numbering	6
1.3	System Design	7
1.4	Technical Specifications	8
1.5	Environmental Specifications	12
2	Safety	13
2.1	Safety Symbols	13
2.2	Safety Guidelines	13
2.3	Compliance	14
3	Installation	15
3.1	Unpacking and Packing	15
3.2	Mounting	15
3.2.1	Mounting the AGD155	15
3.2.2	Mounting Multiple AGD155 Units	16
3.3	Electrical Installation	17
3.3.1	Power Wiring	17
3.3.2	Regeneration	18
3.3.3	Circuit Breakers	19
3.3.4	AC Line filter	19
3.3.5	Safe Operating Area (SOA)	19
3.3.6	Grounding	21
	Ground Domains	21
	Grounding Policy	22
3.3.7	PT100/PT1000 Temperature Sensors	22
3.4	Electrical Interfaces	23
3.4.1	Interface X10: Main Power	23
3.4.2	Interface X14: I/O and Brake Power	24
3.4.3	Interface X7: Motor	25
	For Brushless Motor	25
	For Brush (or Voice Coil) Motor	25
3.4.4	Interface X15: Safety	26
	Safety Circuitry	27
3.4.5	Interface X8: Static Brake	28
	Brake Circuitry	28
3.4.6	Interface X9: Regeneration	29
3.4.7	DIP Switches	30
3.4.8	Interface X13: Ethernet (LAN)	31
3.4.9	Interfaces X11, X12 – Fieldbus	32
3.4.10	Interface X1: Micro USB	34
3.4.11	Interface X2: Main Encoder	35
3.4.12	Interface X3: Auxiliary Encoder	36
3.4.13	Interface X4: Hall Sensors	38
	Hall Sensor Circuitry	39
3.4.14	Interface X5: System I/Os	40
3.4.15	Interface X6: Control I/Os	42
3.4.16	I/O Interfaces – Circuitry	44
	Isolated Digital Inputs 1 to 3, 5 to 9, and 12 to 16	44
	Isolated Digital Input 4	44
	Isolated Digital Outputs 1 to 2, and 3 to 6	45
	Differential Inputs 1 to 3	46
	Differential Outputs 1 to 4	46
	Bi-Directional Differential I/O	47

	Analog Inputs 1 to 2	47
	Analog Outputs 1 to 2	48
4	Operation	49
4.1	Motor Configuration	49
4.2	Drive/Motor Overload Protection	51
4.2.1	I ² T Overload Protection	51
4.2.2	Motor Stuck	53
4.2.3	Motor Temperature Protection	53
4.3	Tuning	54
4.3.1	Commissioning	54
4.3.2	Current Loop Tuning	55
4.3.3	Auto Velocity and Position Loop Tuning	56
4.3.4	Manual Velocity and Position Loop Tuning	59
5	Maintenance and Servicing	61

1.3 System Design

Note: For single-phase wiring: AC connects to L1 and L2

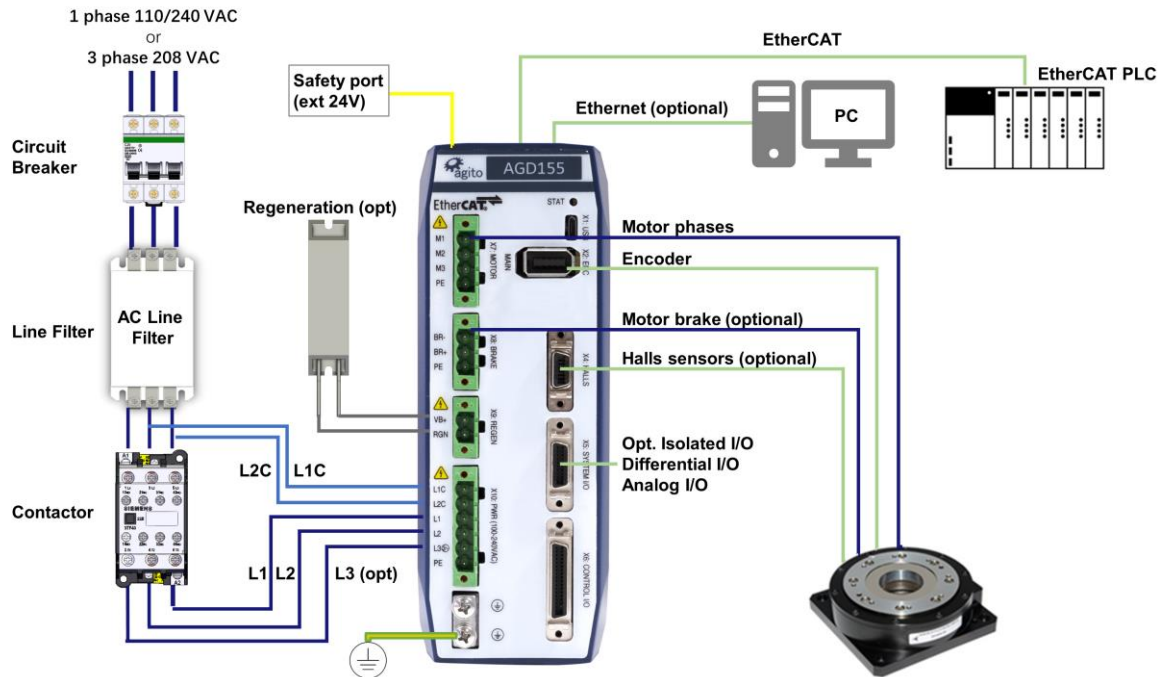

Figure 2. System connections and wiring – AGD155-EC

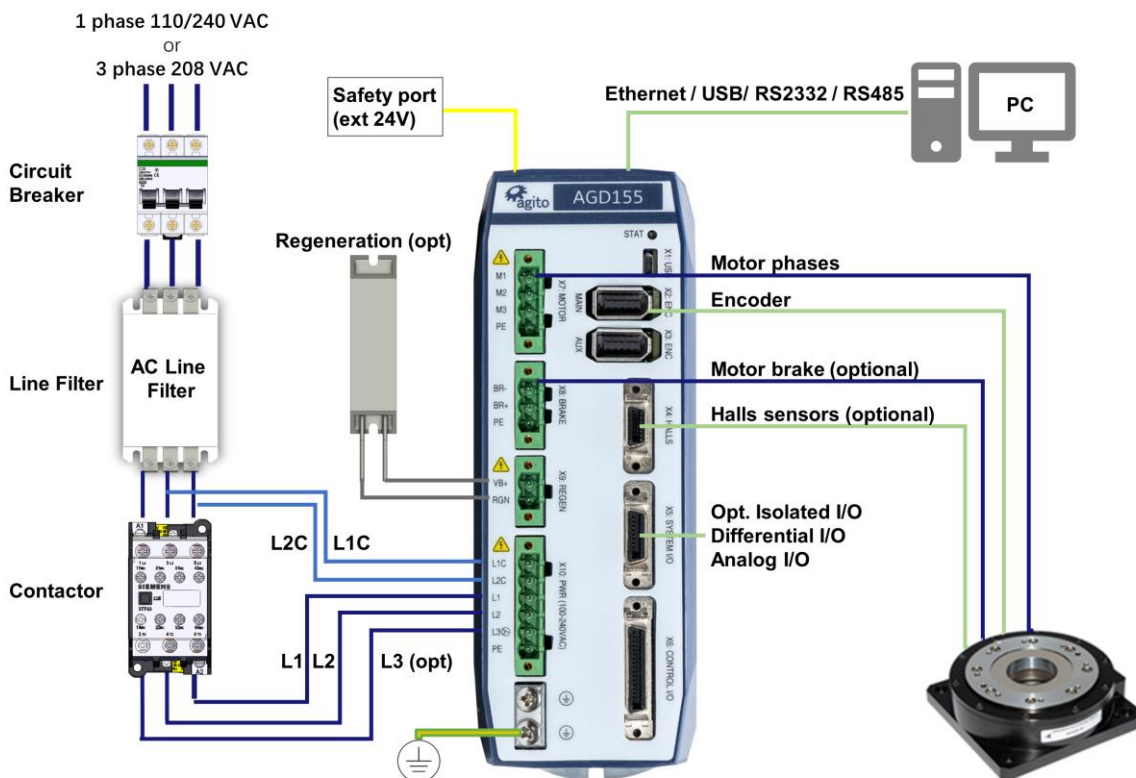

Figure 3. System connections and wiring – AGD155-AF

1.4 Technical Specifications

Electrical/Mechanical Specifications

Feature	AGD155-xx-2A06	AGD155-xx-2A10
Number of axes	1	
Nominal supply voltage	1-phase: 110–240 VAC L-N, 50–60 Hz 3-phase: 120 VAC L-L, 50–60 Hz	
Minimum supply voltage	1-phase: 71 VAC L-N 3-phase: 41 VAC L-L	
Maximum supply voltage	1-phase: 276 VAC L-N 3-phase, 160 VAC L-L	
Continuous output current (internally limited by firmware)	6 A _{rms}	10 A _{rms}
Peak output current (internally limited by firmware)	18 A _{rms}	20 A _{rms}
Output power @ 110 VAC	0.66 kVA	1.1 kVA
Output power @ 240 VAC	1.44 kVA	2.4 kVA
Input current @ 1-phase 110–240 VAC	9 A _{rms}	15 A _{rms}
Input current @ 3-phase 208 VAC	6 A _{rms}	10 A _{rms}
Peak current time	1.5 sec	
Output frequency	0 – 599 Hz	
Short-circuit rating	Rated short-circuit breaking capacity: 5 kA*	
Isolated digital inputs	16	
Isolated digital outputs	4	
Differential digital inputs	3	
Differential digital outputs	4	
Bi-directional differential digital I/Os (RS422)	1	
Analog inputs	AGD155- EC : 1 (12 bit) AGD155- AF : 2 (16 bit)	
Analog outputs	AGD155- EC : NA AGD155- AF : 2	
PT100/PT1000 inputs	1	
Brake outputs	1	
Regeneration outputs	1	
Encoder ports	2	
Hall sensors ports	1	
Motor types	Voice coil, brushed or brushless linear or rotary motor. 2-phase steppers (open and closed loop, micro-stepping)	
Communication	AGD155- EC : EtherCAT, Ethernet, USB AGD155- AF : Ethernet, USB, CAN, RS232, RS485	

Feature	AGD155-xx-2A06	AGD155-xx-2A10
PWM Frequency	16 kHz	
Power supply to external devices	Voltage: 5V Overall max. current: 1.5A	
Maximum leakage current	6 mA	
AC logic power inrush current	Max current: 2A Max duration: 1 ms	
AC main power inrush current	Max current: 7.8A Max duration: 20 ms Note: controlled by soft start	

* During compliance testing, the short-circuit current was 200A

Encoder Ports Specifications

Feature	Specification
Encoder types	Incremental AqB, Sin/Cos Absolute: EnDat 2.2, BiSS-C
Power supply to encoder	0.5 A per encoder port
Max. cable length	40 m
Incremental encoder	Hardware: Differential RS422/RS485 Max. input frequency: 6.25 MHz Termination: 120 Ω Commutation: Auto-phasing, Hall sensors
Sin/Cos encoder (available on Main Encoder port only)	Hardware: Differential RS422/RS485, 1V pkp @2.5V Max. input frequency: 250 kHz Termination: 120 Ω Max interpolation: 13 bits (x 8192) Commutation: Auto-phasing, Hall sensors
Absolute BiSS-C	Hardware: Differential RS422/RS485, clock (MA), data (SLO) Clock frequency: 1 MHz Max. position bits: 32 bits Commutation: Auto-phasing, by absolute offset
Absolute EnDat 2.2	Hardware: Differential RS422/RS485, clock, data Clock frequency: 1 MHz Max. position bits: 32 bits Commutation: Auto-phasing, by absolute offset
Hall sensors	Opto-isolated 5V with internal or external power supply

I/O Specifications

Feature	Specification
Power supply for optically isolated I/Os	Voltage: 5–28 VDC
Optically isolated digital inputs	Type: PNP/NPN Propagation delay: 10 μ s Max. frequency: 100 kHz Functionality: limit switches, home, captures, start motion, gain scheduling, and others
Optically isolated digital outputs	Type: PNP/NPN Max current: 0.5A (for NPN type), 0.3A (for PNP type) Propagation delay: 10 μ s Max. frequency: 100 kHz Functionality: alarm, in-position, event (PEG), and others
Differential digital inputs	Hardware: Differential RS422 Termination: 120 Ω Propagation delay: 100 ns Max. frequency: 5 MHz Functionality: Position lock (capture), pulse and direction, AqB encoder following, Handwheel
Differential digital outputs	Hardware: Differential RS422 Termination: NA Propagation delay: 100 ns Max. frequency: 5 MHz Functionality: Position event, encoder emulation, alarm, statuses, and others.
Bi-directional differential digital I/O	Hardware: Differential RS422 Termination: 120 Ω Propagation delay: 100 ns Max. frequency: 5 MHz Direction: Input or output, set by Agito PCSuite Functionality: Any differential input or output functionality.
Analog inputs	Operational voltage: \pm 12V Resolution: 16 bit
Analog outputs	Operational voltage: \pm 12V Resolution: 16 bit
Safety inputs	2 independent inputs Voltage: 5–28 VDC
Static brake output	Operational voltage: 24V Maximum current: 3A
Temperature sensors inputs	PT100 or PT1000. Refer to the section PT100/PT1000 Temperature Sensors.

Dimensions and Weight

Feature	Specification
Unit dimensions (max)	H=196.97 mm, W=65.80 mm, D=158.60 mm
Package dimensions	244 mm x 92 mm x 198 mm
Unit weight	1.29 kg
Shipping weight	1.44 kg

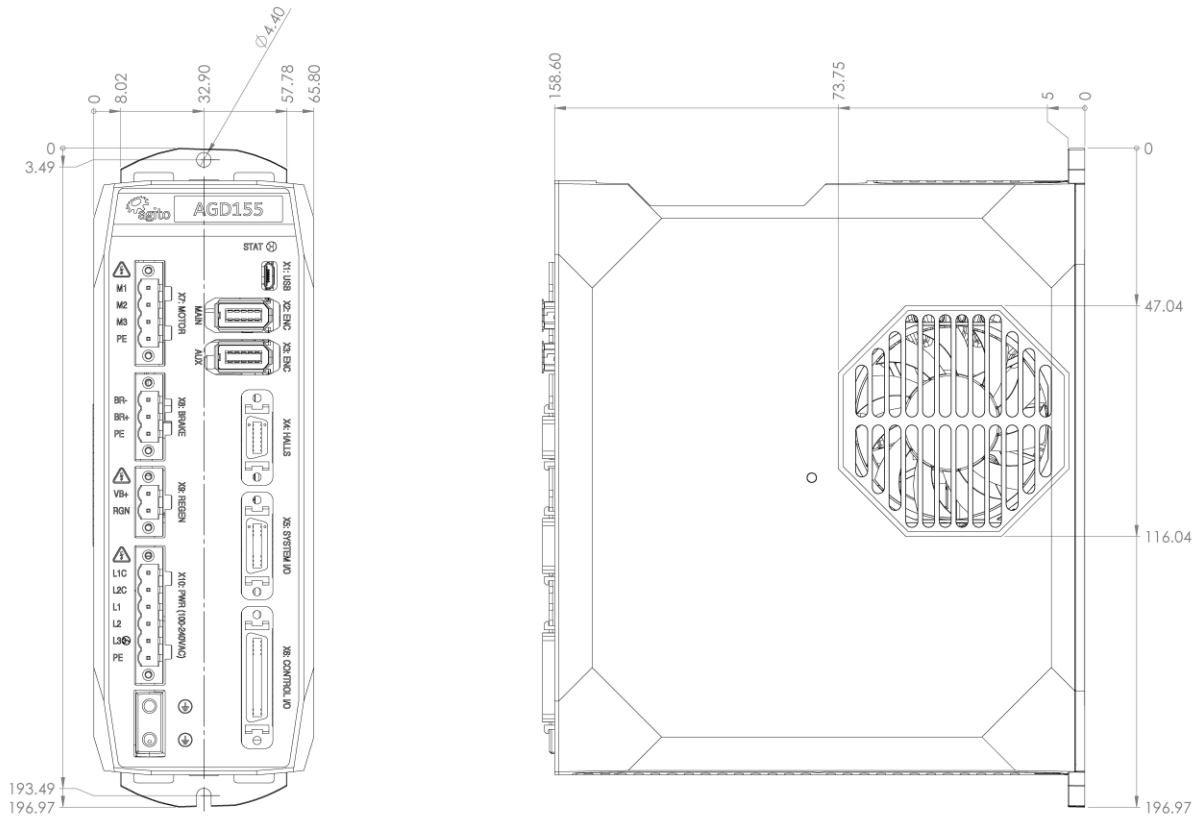

Figure 4. Product Dimensions (mm)

1.5 Environmental Specifications

Environmental Specifications

Feature	Specification
Operating temperature*	AGD155-xx-2A06: 0°C to 50°C AGD155-xx-2A10: 0°C to 40°C
Storage temperature	-20°C to 70°C
Operating humidity	< 90%
Storage humidity	< 40%
Pollution degree	2
Vibration	1G @ 150 Hz according to IEC 60068-2-6
Operating conditions	Protection class: IP20

* The operational range may be additionally limited by the internal temperature protection of the product. Refer to the section Safe Operating Area (SOA). However, it is the user's responsibility to avoid operating the product in environmental conditions that do not conform to the defined limits.



2 Safety

2.1 Safety Symbols

Safety symbols indicate a potential for personal injury or equipment damage if the prescribed precautions and safe operating practices are not followed.

The following safety symbols are used in the product documentation.

Safety Symbols

Symbol	Meaning	Description
	Hazardous voltage	Indicates hazards arising from dangerous voltages.
	Earthing PE (protective earth)	Identifies any terminal which is intended for connection to an external conductor for protection against electric shock in case of a fault, or the terminal of a protective earth (ground) electrode.
	Caution, hot surface	Indicates the marked item can be hot and should not be touched without taking care.

2.2 Safety Guidelines

To achieve optimum and safe operation of the product, it is important to follow the safety procedures specified in this manual.

Only qualified personnel may install, maintain, or repair the product. Before starting installation, maintenance or operation, ensure that all system components are connected to protective earth ground (PE).

The PE wire must be colored green-yellow, in accordance with local electrical wiring standards.

This product contains electrostatic-sensitive components. Proper handling procedures must be observed to avoid damage to the product.

To avoid electric arcing and hazards, never connect or disconnect any connector while the power source is on.

The maximum power supply voltage connected to the product must comply with the ratings provided in this manual.

Always disconnect the power cables before servicing the product.

Pay attention to safety symbols on the product or in the manual. Follow proper safety precautions when installing or operating the product.



Attention

All power connectors must be securely tightened before any operation.



Warning

Connectors X10, X9, and X7 are high power. Do not touch these connectors when the product is powered.



Warning

Capacitors on the DC bus can retain hazardous voltages after input power has been removed. Discharge time to below 60 VDC is 10 minutes.

Wait until the red LED (charge indicator) shuts off before physically touching the product. The product must not be opened or serviced until the discharge is complete. Failure to observe this precaution could result in severe bodily injury or loss of life.



Attention

Do not attempt to hinder or override the product's or system's fault detection or protection circuits. You must determine the cause of a fault and correct it before you attempt to operate the system. Failure to correct the fault could result in personal injury and/or damage to equipment.

2.3 Compliance

Standards Compliance

Description	Standard
Safety requirements – Electrical, thermal and energy	IEC-61800-5-1
EMC requirements and specific test methods	IEC-61800-3

This product is intended to operate in a machine or equivalent end-product. The machine or end-product must comply with any necessary safety standard as typically required for the same type of machine or end-product. It is the responsibility of the machine or end-product manufacturer to ensure the final machine or end-product meets the requirement of any safety and EMC regulations.

3 Installation

3.1 Unpacking and Packing

Save the original box and packing materials in case you need to pack and return the product to the manufacturer.

To unpack the product:

1. Carefully remove the product from the box and the packing materials.
2. Visually inspect the product to ensure that there is no damage. If any damage has occurred, report it immediately to the carrier that delivered the package.
3. After unpacking, locate the part number label on the product, and make sure it matches the product you ordered, and that the voltage meets your specific requirements.

3.2 Mounting

3.2.1 Mounting the AGD155

The heatsink on the back of the AGD155 includes a hole (at top) and a slot (at bottom) for mounting the unit. The AGD155 must be mounted vertically (book mounting), as shown in Figure 4.

The AGD155 is mounted using 2 M4 screws. It is important to mount the product on metal panel for both grounding and secure connections.

The heatsink of the AGD155 is electrically conductive and serves as the protective earth (PE) ground of the product. However, it is critical to ensure the PE screws are electrically conducting between the PE of AGD155 and the PE of main power supply in the system.

All cables connected to the product must be securely constrained to avoid vibration that causes stress concentration at the cables or connectors which may result in breakage of electrical conductivity.



Warning – Metal Base Plate for Heat Dissipation

The product is supplied with the mounting plate built into the heatsink. At full power operation, the heatsink can be quite warm, around 45°C. It is recommended to mount the product on a large metal panel to help dissipate the heat generated in the product.

3.2.2 Mounting Multiple AGD155 Units

When mounting multiple AGD155 units within a cabinet, clearance between units must be at least 10 mm. In addition, top and bottom clearance must be at least 50 mm.

Ambient temperature in the cabinet must not exceed the limit defined in section Safe Operating Area (SOA).

If units are mounted on a backplane, the backplane temperature must not exceed the limit defined section Safe Operating Area (SOA).

It is recommended to install a cooling fan at the bottom of the cabinet for best circulation.

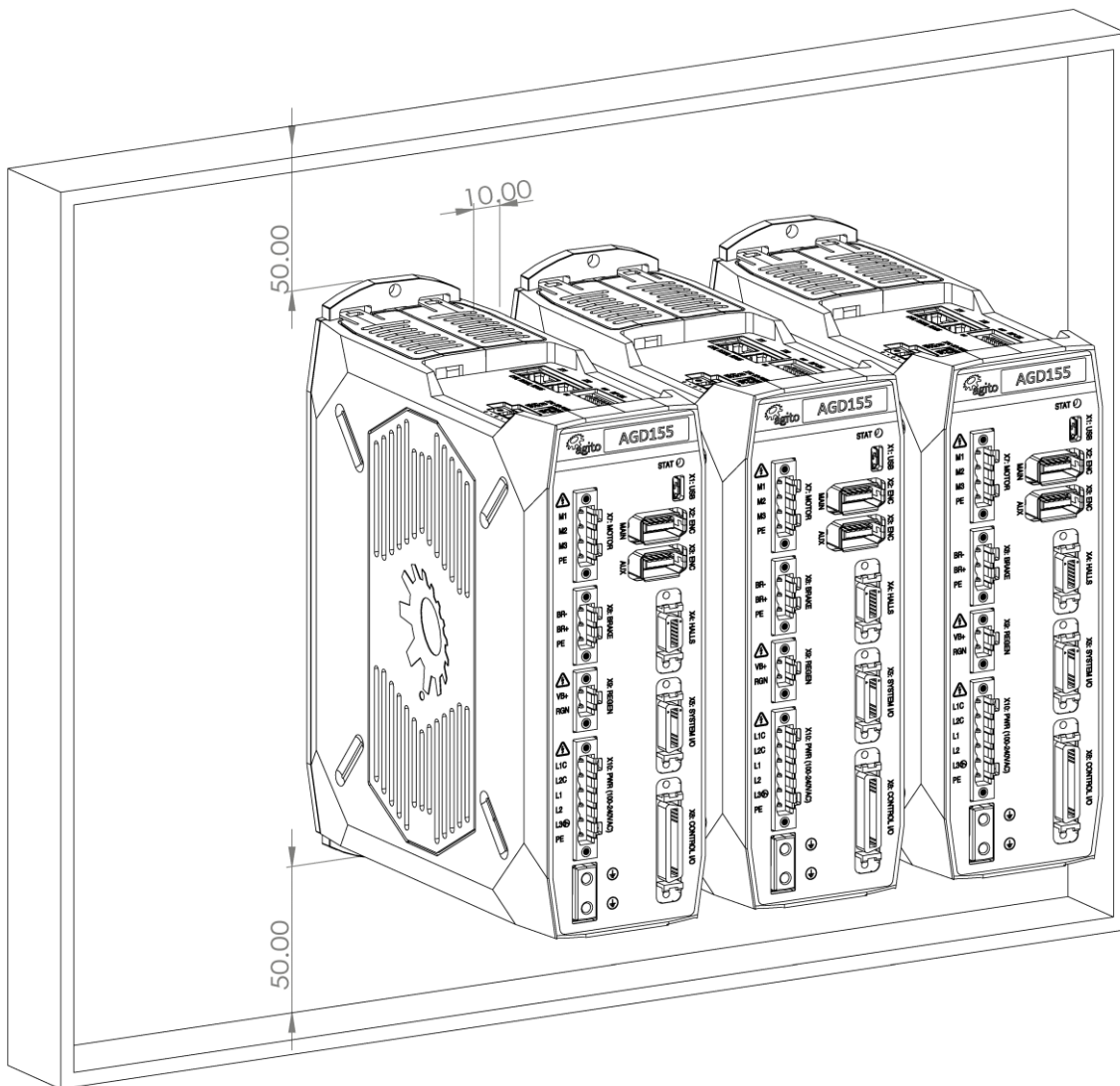

Figure 5. Mounting multiple units within cabinet

3.3 Electrical Installation

3.3.1 Power Wiring

AGD155 is designed to operate directly from 110 VAC to 240 VAC mains power, which is supplied to bus voltage, motor, and logic power.

Logic power input (L1C, L2C) uses 1-phase 110–240 VAC input.

Motor power input (L1, L2, L3) uses either of the following:

- 1-phase 110–240 VAC input
- 3-phase 208 VAC input



Note – Wiring

In single phase wiring, L1 and L2 must be wired to 1-phase 110/240 VAC.

In three phase wiring, L1, L2 and L3 must be wired to 3-phase 208 VAC.

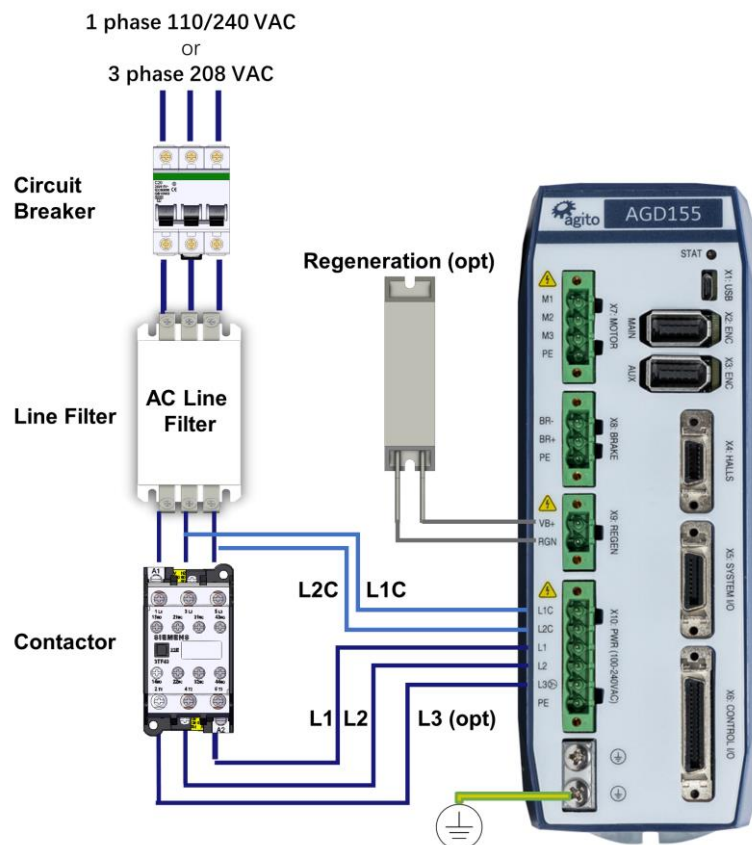

Figure 6. Power supply wiring

3.3.2 Regeneration

AC power input is converted to DC bus, and outputs a controlled electrical power through the phases of the motor. The motor converts this electrical power to a mechanical power that moves the load.

During motor deceleration and stopping, the inertia of the load drives the movement of the motor, not the servo drive. Due to back EMF, the motor acts as a generator and returns energy to the DC bus supply, which causes the DC bus voltage to increase to undesirable level.

Maximum allowable DC bus voltage is 390 VDC. To control the DC bus voltage, a regeneration resistor can be connected to the servo drive to dissipate excess regenerated energy, and prevent it from reaching undesirable levels. The regeneration resistor starts to dissipate energy at 370 VDC (default); this value is user-configurable.



Warning

DC Vbus is monitored, and motors will be disabled if voltage is too high. However, there is no protection against the connection of an excessive voltage power supply that will damage the product.

For connection details, refer to the section *Interface X9: Regeneration*.

Important Notes

- The regeneration feature, once enabled, is always active, regardless of the motor status (enabled/disabled).
- Current will flow in the regeneration resistor depending on the values of RegenOn and RegenOff, and the power supply voltage.
- There are no current or power protections to protect the regeneration resistor or the internal MOSFET.
- Be sure to set the suitable regeneration parameters for the supply voltage and the external regeneration resistor.
- Plug in the regeneration resistor only after all parameters are set properly, and always when the controller power is off.
- Let the regeneration resistor cool down before touching it. Unplug it only when the controller power is off.
- During development, if the supply voltage is to be modified, first disconnect the regeneration resistor and, before reconnecting the regeneration resistor, be sure to adjust the regeneration parameters to match the new supply voltage.
- We recommend adding external protections (such as PTC) to protect the regeneration resistor.

3.3.3 Circuit Breakers

Circuit Breaker Specifications

Feature	Specification
Circuit breaker type	Type C. 2-pole for L to N. 3-pole for 3-phase.
Fuse type	Time delay / slow blow
Current rating	AGD155 10A: 25 A AGD155 6A: 10 A
Voltage rating AC	600 VAC
Interrupt rating	minimum 10 kA

Example: Schneider Electric iC60N 3P 6A C

3.3.4 AC Line filter

For proper product operation, an external AC line filter is required. Refer to Figure 6. Power supply wiring. The AC line filter prevents external transients and spikes on the power line from entering the product enclosure. Such interference may be caused by other AC powered devices being turned on and off, and by motors running on the same power subsystem

AC Line Filter Specifications

Feature	Specification
Filter type	2-stage AC line filter
Current	20 A
Voltage	250 VAC
Antennation frequency	From 100 kHz to 50 MHz

Example: Würth Elektronik 810913020

3.3.5 Safe Operating Area (SOA)

While each specific maximal rating can be safely used, the product cannot support certain combinations of these maximal ratings. For example, the product will not enable operation under the following **combined** maximal ratings usage continuously over long-term period:

- Continuous current at $6A_{rms}$, at 90% PWM duty cycle
- 1.5A external load on the 5V supply
- Product mounted horizontally and not attached to a suitable base plate
- 55°C ambient temperature

Permitted combinations, as well as forbidden combinations, cannot be specifically provided since they are a function of multiple conditions, such as continuous current, bus voltage, PWM duty cycle, 5V consumption, I/O's high current usage, mounting base plate size, product mounting orientation, and ambient temperature.

The SOA of the product is defined as any combination of operational conditions (each within the absolute maximal ratings defined in the Technical Specifications) and assembly options that lead to internal product temperature below 80°C.

The product includes a built-in temperature sensor. Its internal temperature is reported via the status parameter PwrTemp (integrated power module temperature). When PwrTemp reaches 80°C,

the motor will be disabled and an error will be reported. A motor-enable request will create an error if PwrTemp is higher than 80°C.

The following figure shows examples of safe operating cases for AGD155-xx-2A06. The SOA charts assume 90% duty cycle on PWM output continuously; that is, motors are moving at the maximum speed allowed by the bus voltage.

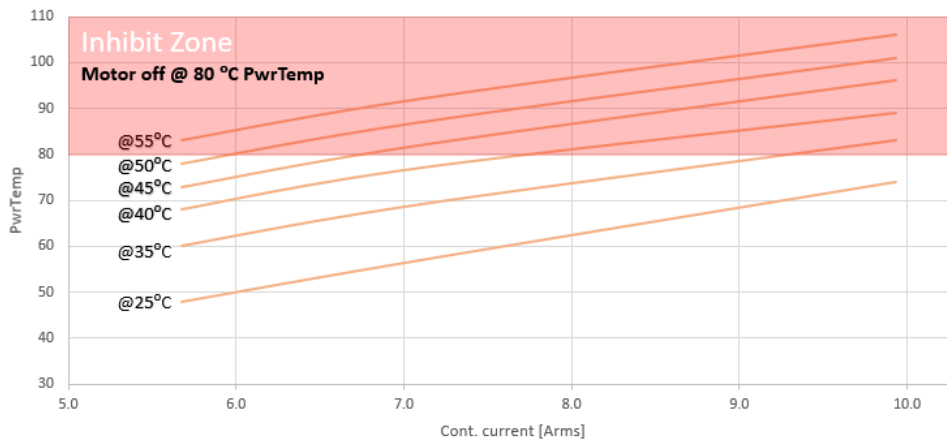

Figure 7. Current/Temperature



Attention

Each of the power/voltage/current absolute maximal ratings is valid over the overall operating temperature range, subject to the safe operating area (SOA).



Attention

Operating (or storing) the product contrary to the defined absolute maximal ratings is not allowed and will damage the product.

3.3.6 Grounding

It is recommended to install the AGD155 on a metal plate for better power dissipation, reduced EMI, and grounding connection. Make sure the plate is not painted.

The heatsink of the AGD155 is electrically conductive and serves as the protective earth (PE) ground of the product. However, it is critical to ensure the PE screws are electrically conducting between the PE of AGD155 and the PE of main power supply in the system.

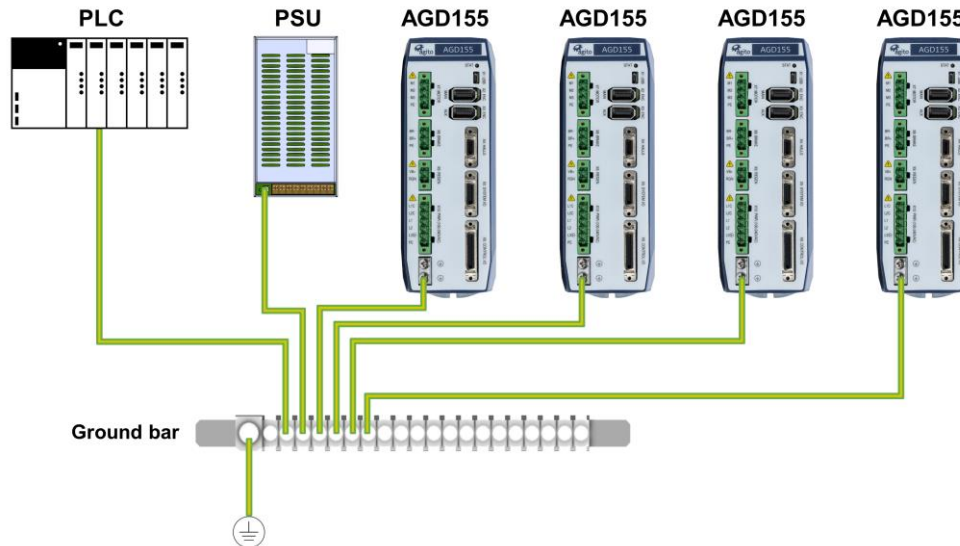

Figure 8. System grounding

Ground Domains

The following table shows the ground domains in the AGD155 system:

- GND. Reference voltage for digital/analog circuits and signals.
- PGND. High voltage ground domain (internal)
- General. Usually at DC potential close to GND, but not connected internally.

Ground Domains

Name	Ground Domain	Notes
DC power input	GND (I/O return)	External DC power supply
AC power input	PGND (power ground only)	Internal PGND
Isolated digital inputs/outputs	General	Isolated
Differential inputs/outputs (not isolated)	GND	To controller/PLC
Analog inputs/outputs (not isolated)	GND	
Brake control output	General	External DC power supply
Regeneration output	PGND	External shunt resistor
Ethernet communication	General	Isolated
Other communication	GND	Not isolated (unless otherwise stated in manual)

Grounding Policy

Grounding of the product must comply with the following guidelines:

- The enclosures and other external parts that may be touched by the user are in the **safe domain**.
- The AGD155 must be connected to protective earth (PE) and connected to the building's ground. PE is protected with an earth-leakage circuit breaker (ELCB); hence it is safe to touch. Refer to Figure 8.
- PGND is connected directly to mains wires, hence it is just as dangerous as mains to the user.
- All shielded cables, including but not limited to motor, encoders, and power input, have their shield connected to PE as part of the external metal enclosure.
- PGND is bypassed to PE with low capacitance (around 10 nF) for EMI/EMC purposes.
- It is critical to avoid ground loops in the system. A ground loop allows currents to return by two or more different paths, causing electromagnetic interference or even damage to wires.
- The system designer must carefully examine all GND connections in the system to ensure that no loops are created, and that all GND-referenced signals have a GND wire nearby (for both return currents and common mode voltage).

3.3.7 PT100/PT1000 Temperature Sensors

AGD155 supports two types of temperature sensors:

- The PT100 temperature sensor is a platinum resistance thermometer. Its resistance value at 0°C is **100Ω**.
- The PT1000 temperature sensor also a platinum resistance thermometer. Its resistance value at 0°C is **1000Ω**.

The temperature sensor is wired to the X4 connector as shown in the following table.

PT100/PT1000 Temperature Sensor Wiring

Pin #	Pin Name	PT100	PT1000
3	PT1000_EN	NC	Short to pin 6
6	GND	NC	Short to pin 3
8	RTD+	PT100+	PT1000+
9	RTD-	PT100-	PT1000-

3.4 Electrical Interfaces

This section provides a detailed description of all the power and signal interfaces of the AGD155.

3.4.1 Interface X10: Main Power

Connector X10 is used to supply AC power to the AGD155.



Supply voltages for the AGD155 are as follows:

- Nominal supply voltage: 1-phase: 110–240 VAC L-N, 50–60 Hz
3-phase: 120 VAC L-L, 50–60 Hz
- Minimum supply voltage: 1-phase: 71 VAC L-N
3-phase: 41 VAC L-L
- Maximum supply voltage: 1-phase: 276 VAC L-N
3-phase, 160 VAC L-L

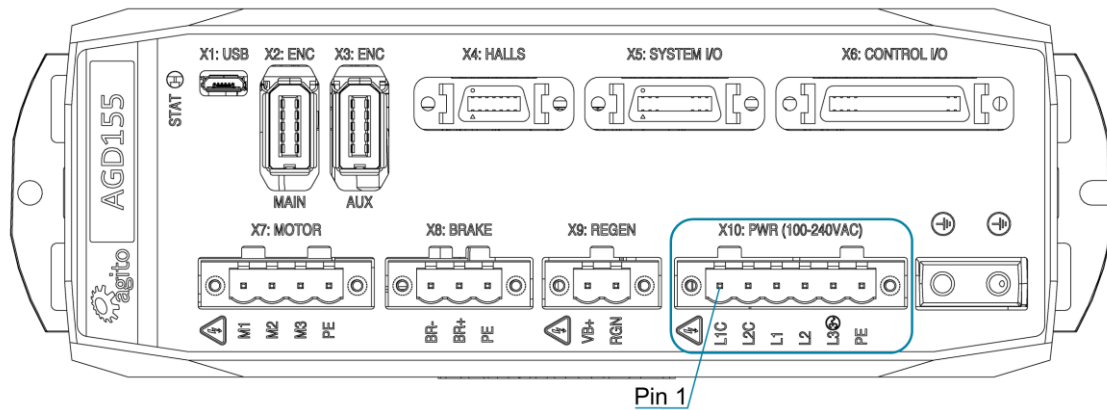

Figure 9. Power Connector

Connector X10: PWR

Pin #	Name	Description
1	L1C	AC logic power
2	L2C	AC logic power
3	L1	AC main power
4	L2	AC main power
5	L3 (3-phase)	AC main power for 3-phase power input
6	PE	Protective earth

Mating connector options	Degson 2EDGKDM-5.08-6P-14 Phoenix Contact 1942523 Wurth Elektronik 691359740006
Pitch	5.08 mm
Wiring	14 AWG, insulation rated for 600 V



Mains connections

Connect L1, L2 and L3 for main bus power.
 If the main voltage is from a single-phase source, connect line and neutral to L1 and L2.
 If the main voltage is from a three-phase source, connect the phase to L1, L2 and L3.
 Connect line and neutral to L1C and L2C for logic power.



Warning - Hot plugging is not supported!

Plug or unplug the power connector only when power is off and after the bus LED has turned off (red LED visible at the side of the product). Plugging the power connector when power is on may cause power surges through connected devices and possibly damage them.

3.4.2 Interface X14: I/O and Brake Power

Connector X14 allows the user to provide a DC power supply to the isolated I/Os and motor brake. Typically, the isolated I/Os use 24 VDC. The I/O power is internally connected to each I/O port to allow users to tap this power supply easily within the same connector.

The brake power support up to 48 VDC. This power is internally connected to the brake output port.

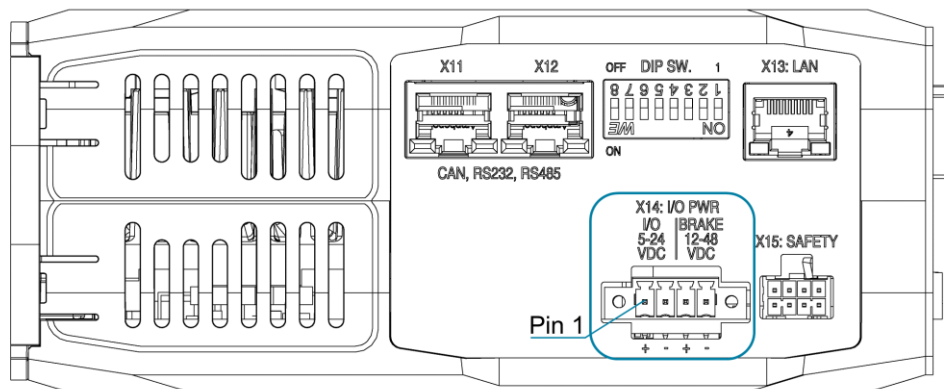

Figure 10. I/O and Brake Power Connector

Connector X14: I/O PWR

Pin #	Name	Description
1	IO_PWR	5 to 24 VDC – User supplied I/O power input, up to 2A
2	IO_PWR_Return	Ground – I/O power return
3	VBrake	12 to 48 VDC – Brake power input, up to 70W
4	VBrake_Return	Ground – Brake power return

Mating connector options	Degson 15EDGKDM-3.5-04P-1 Phoenix Contact 1966114 Würth Elektronik 691364100004
Pitch	3.5 mm
Wiring	AWG 18, insulation rated for 100 V



Warning - Hot plugging is forbidden!

Plug or unplug the power connector only when power is off! Plugging the power connector when power is on may cause power surges through connected devices and possibly damage them.

3.4.3 Interface X7: Motor

Connector X7 supplies power to the motor, which can be a 3-phase brushless motor, or a 1-phase brushed motor or voice coil motor.

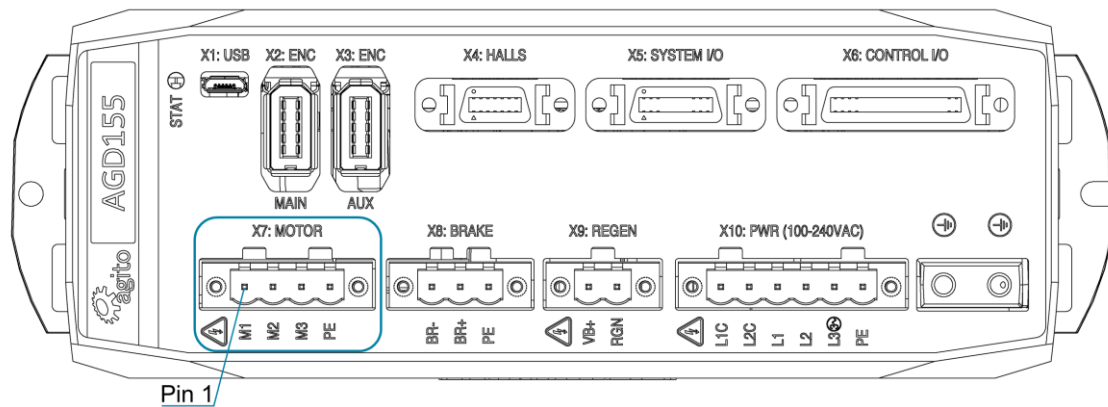

Figure 11. Motor Connector

For Brushless Motor

Connector X7: MOTOR (Brushless Motor)

Pin #	Name	Description
1	Phase A	Motor phase A (M1)
2	Phase B	Motor phase B (M2)
3	Phase C	Motor phase C (M3)
4	PE	Protective earth (motor power cable shield)

Mating connector options	Degson 2EDGKDM-5.08-4P-14 Phoenix Contact 1942507 Wurth Elektronik 691340500004
Pitch	5.08 mm
Wiring	14-16 AWG, insulation rated for 600 V

For Brush (or Voice Coil) Motor

Connector X7: MOTOR (Brushed or Voice Coil Motor)

Pin #	Name	Description
1	Motor Phase +	Positive terminal, phase A or M1
2	Motor Phase -	Negative terminal, phase B or M2
3	NC	Do not connect
4	PE	Protective earth (motor power cable shield)

Mating connector options	Degson	2EDGKDM-5.08-4P-14
	Phoenix Contact	1942507
	Wurth Elektronik	691340500004
Pitch	5.08 mm	
Wiring	14-16 AWG, insulation rated for 600 V	

3.4.4 Interface X15: Safety

Connector X3 is used for the hardware safety function that disables power to the motor.

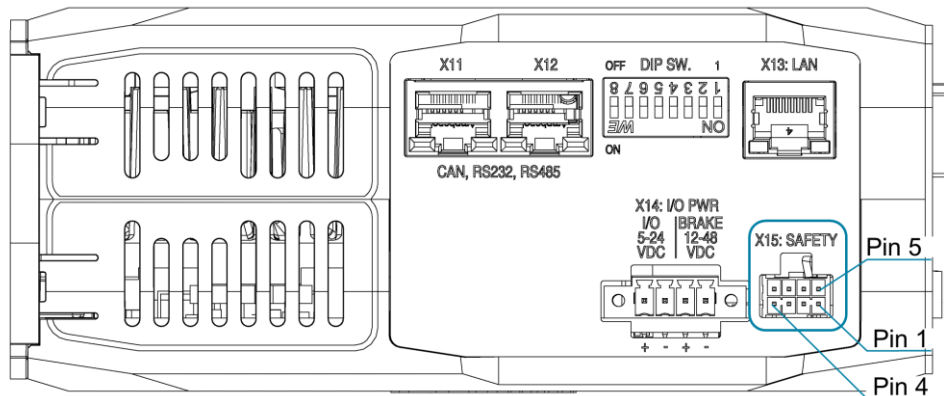

Figure 12. Safety Connector

Connector X15: SAFETY

Pin #	Name	Description
1	5V	5V supply for safety circuits
2	Safety_Feedback-	Safety_Feedback negative (emitter) output
3	Safety_Input_2-	Safety_Input_2 negative input
4	Safety_Input_1-	Safety_Input_1 negative input
5	GND	GND
6	Safety_Feedback+	Safety_Feedback positive (collector) output
7	Safety_Input_2+	Safety_Input_2 positive input
8	Safety_Input_1+	Safety_Input_1 positive input

Mating connector options	Samtec	IPD1-04-D-K
Crimp	Samtec	CC79L-2630-01-L
Wiring	26 AWG, insulation rated for 100 V	



Disabling Safety function

If the Safety function is not required in your application, you can disable it by using a jumper plug from Agito. Part number: C-AGD301-SFT

Safety Circuitry

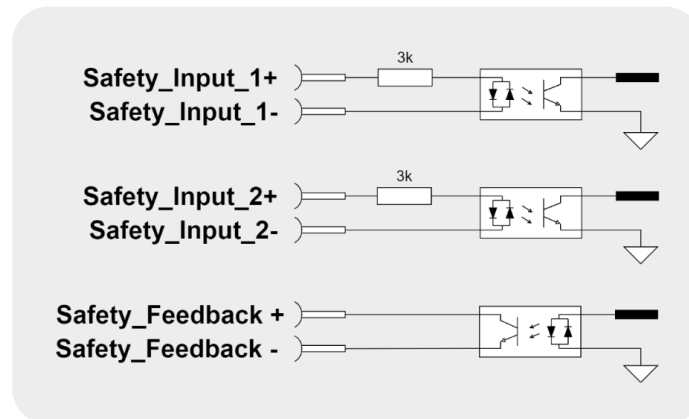

Figure 13. Safety

- The safety circuitry consists of two input channels, labeled Safety_Input_1 and Safety_Input_2. Both input channels support a voltage range of 5 VDC to 24 VDC. It is recommended to use 24 VDC for the input voltage as it provides better electromagnetic interference (EMI) immunity.
- Safety_Input_1 and Safety_Input_2 function independently, thus providing safety redundancy. Each one can disable the power to the motor.
- Both Safety_Input_1 and Safety_Input_2 disable the power to the motor through hardware circuitry, without any software intervention.
- Both Safety_Input_1 and Safety_Input_2 are defined with a positive pin (+) and a negative pin (-). However, the opto-coupler at the Safety_Input has two input diodes, which enable operation at "positive" or "negative" input voltage. The input is activated when current is sufficient at one of the input diodes, regardless of the current direction. This enables NPN or PNP connection to the safety inputs.
- The Safety_Input protection logic is designed so that both Safety_Inputs must be powered to enable motor operation. Leaving a Safety_Input disconnected prevents motor operation. This logic is required to ensure that a disconnected safety cable is considered an unsafe condition by the control unit. When sufficient current is driven through a Safety_Input, the state of this input is **Safe**. When insufficient current is driven through a Safety_Input, the state of this input is **Unsafe**.
- The two Safety_Inputs must be in the Safe state to enable motor operation.
- Both Safety_Input_1 and Safety_Input_2, although acting on the drive hardware directly, are also monitored by the controller software. The controller software generates a feedback signal to the user (Safety_Feedback), which is also an isolated signal. This feedback is generated by the software, and is activated if at least one of Safety_Input_1 or Safety_Input_2 signals is in the Unsafe state.
- The electrical characteristics of Safety_Input_1 and Safety_Input_2 are identical to those of all other isolated digital inputs of the controller.
- The safety inputs implemented in the product are currently pending certification Functional Safety Standards.

3.4.5 Interface X8: Static Brake

Some motors come with a static brake, which is engaged when the motor is not enabled. Connector X8 provides the interface to connect this static brake.

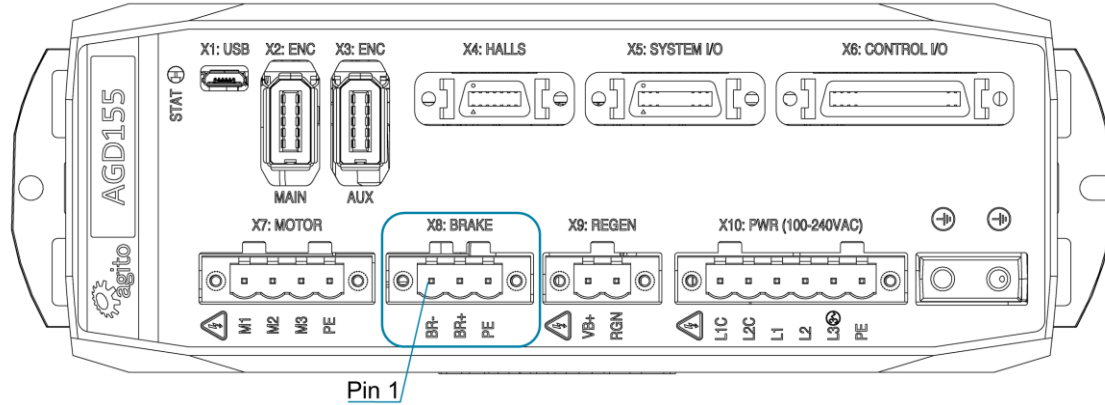

Figure 14. Brake Connector

Connector X8: BRAKE

Pin #	Name	Description
1	BR- (Static_Brake)	Static brake output for motor A. Open-drain output with built-in flyback diode to the VBrake for direct connection into inductive load.
2	BR+ (VBrake)	Power out to brake. Internally connected to X14: I/O PWR Pin-3, VBrake.
3	PE	Protective earth

Mating connector options	Degson 2EDGKDM-5.08-3P-14 Phoenix Contact 1942497 Wurth Elektronik 691340500003
Pitch	5.08 mm
Wiring	18-20 AWG, insulation rated for 100 V

Brake Circuitry

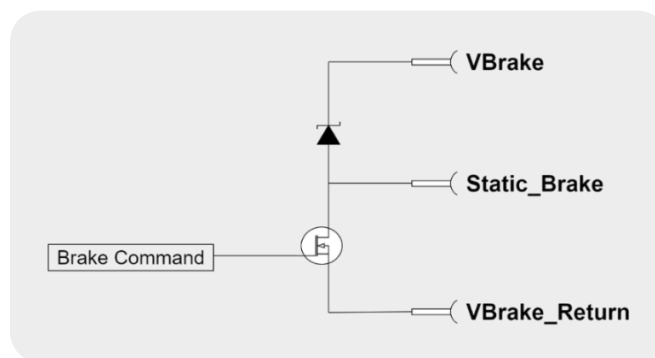

Figure 15. Static brake

3.4.6 Interface X9: Regeneration

Connector X9 is used to connect an external power resistor to dissipate energy generated by the motor, typically during deceleration. The motor-generated energy will charge up the internal capacitor. When the internal capacitor is fully charged, the bus voltage will increase. When bus voltage is higher than the operating limit of the product, it will trigger over-voltage protection and disable the motor. To prevent this from happening, users can connect an external power resistor to dissipate the unwanted energy.

Refer to the section *Regeneration* for more information.

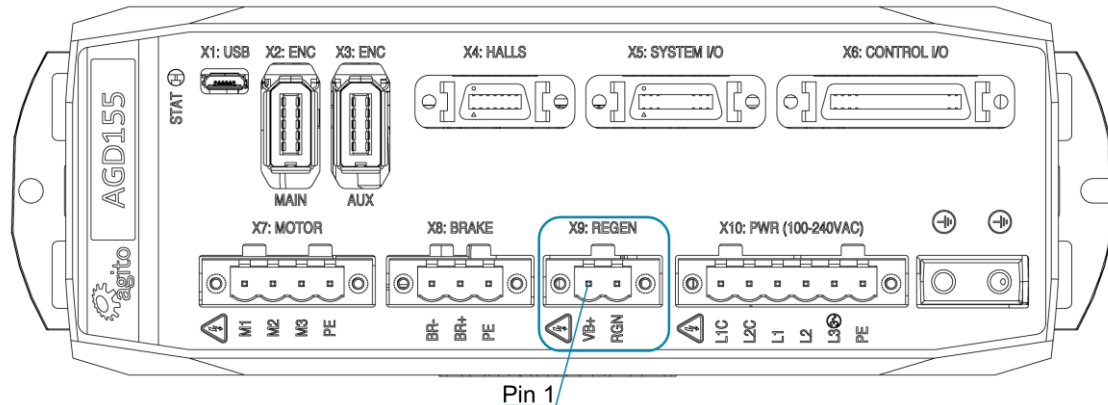

Figure 16. Regeneration Connector

Connector X9: REGEN

Pin #	Name	Description
1	VB+	The internal DC bus power. (Warning: This is typically more than 300 VDC)
2	RGN (Regeneration)	Regeneration pin to be connected to an external regeneration resistor. Designed for 16A (not protected). When Regeneration is triggered, this pin is connected internally to PGND. The other end of the external regeneration resistor should be connected to VB+, the Internal DC Bus power (pin 1).

Mating connector options	Degson 2EDGKDM-5.08-2P-14 Phoenix Contact 1942484 Wurth Elektronik 691340500002
Pitch	5.08 mm
Wiring	14-16 AWG, insulation rated for 600 V

3.4.7 DIP Switches

The AGD155 includes 8 DIP switches to define CAN or Ethernet address offset, to connect a 120Ω CAN terminator resistor, to activate firmware download mode, and set other functions. These are hardware configurations that are typically done only once, during product installation.

The value of the DIP switches, as read by the controller during power on (or reset), can be queried using ADebugData[4] in Agito PCSuite terminal.

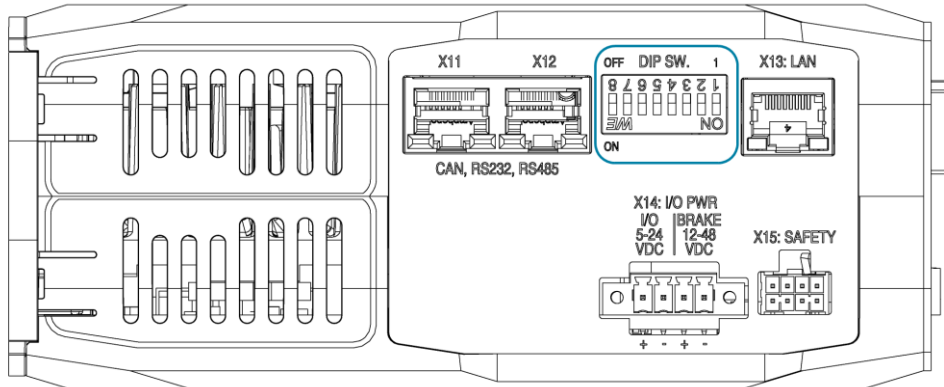

Figure 17 DIP Switches

DIP Switches

DIP Switch #	Function	Description
1	CAN Bus Terminator	Set to ON to connect 120Ω terminator resistor. Only the last unit in the CAN network needs to have this set to ON.
2	Force Download Firmware	Set to ON and power cycle to force the product into firmware download mode. Otherwise, always keep in OFF state.
3	Force Communication to Default	Forces the controller to default communication parameters (bypassing other software parameters in the controller): Ethernet IP: 172.1.1.101 Ethernet Port: 50000 CAN Address: 64 CAN and RS232/USB baud rates are not affected by this DIP switch. Requires power cycle or reset.
4-6	CAN/Ethernet Address Offset DIP Switch 4 – Most significant bit DIP Switch 6 – Least significant bit	DIP switches 4-5-6 create a three-bit value. For example, if DIP switch 4 is set to ON (value of 1), and 5 and 6 are set to OFF (value of 0), the result is: 100 (binary), meaning a value of 4. This value (referred to as <i>offset</i>) is used to define the drive's CAN bus address and Ethernet IP address as follows: Ethernet IP: the actual fourth number of the IP address is equal to: EthernetIP [4] + <i>offset</i> CAN address: the actual CAN address of the unit is equal to: CANAddr + <i>offset</i> * 16 Note: Requires power cycle or reset.
7	Reserved for Future Use	Always keep at OFF state.
8	Reserved for Future Use	Always keep at OFF state.

3.4.8 Interface X13: Ethernet (LAN)

Connector X13 is an Ethernet communication port.

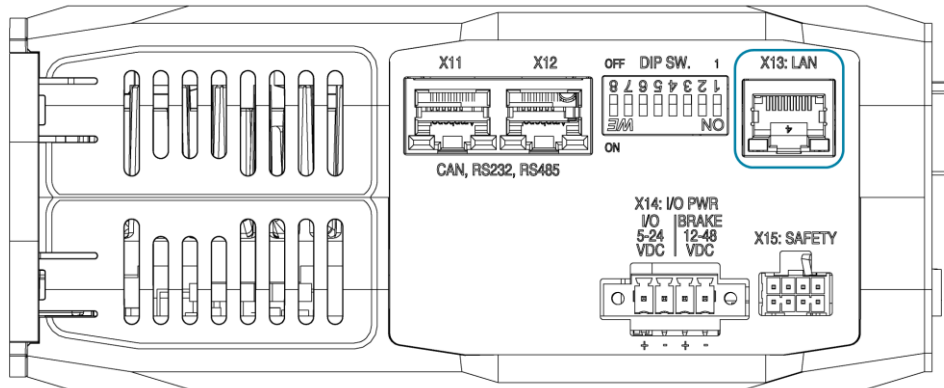

Figure 18: Ethernet Connector

Connector X13: LAN (Ethernet)

Pin #	Name	Description
1	TX+_D1	Transmit data +
2	TX-_D1	Transmit data -
3	RX+_D2	Receive data +
4	BI+_D3	Bi-directional +
5	BI-_D3	Bi-directional +
6	RX-_D2	Receive data -
7	BI+_D4	Bi-directional +
8	BI-_D4	Bi-directional -

Connector type	RJ45 LAN 10/100Base-T connector
Mating connector options	Any CAT5e compatible shielded connector
Cable	CAT5e or higher, standard Ethernet straight cable
Wiring	26 AWG, insulation rated for 100 V

3.4.9 Interfaces X11, X12 – Fieldbus

On the AGD155-EC, connectors X11 and X12 are EtherCAT communication ports.

On the AGD155-AF, connectors X11 and X12 are serial RJ45 communication ports.

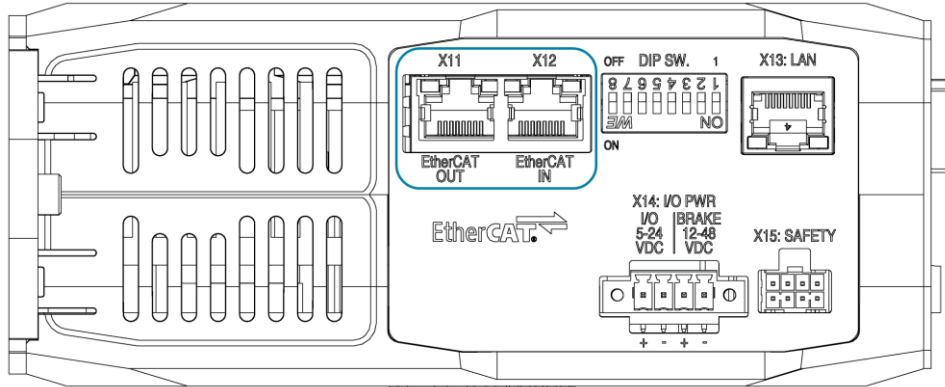

Figure 19: Serial Communication Connectors – AGD155-EC

Connectors X11 and X12: EtherCAT IN and EtherCAT OUT

Pin #	Name	Description
1	TX +	Transmit data +
2	TX -	Transmit data -
3	RX +	Receive data +
4	–	–
5	–	–
6	RX -	Receive data -
7	–	–
8	–	–

Connector type	RJ45 LAN 10/100Base-T connector
Mating connector options	Any CAT5e compatible shielded connector
Cable	CAT5e or higher, standard Ethernet straight cable
Wiring	26 AWG, insulation rated for 100 V

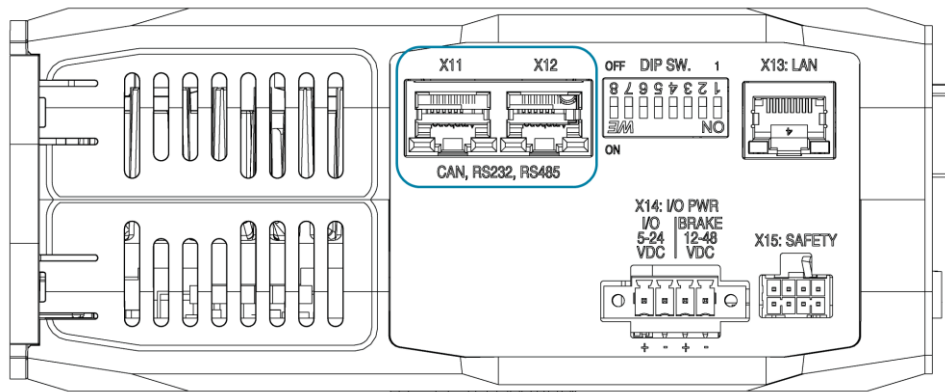

Figure 20: EtherCAT Connectors – AGD155-AF

Connectors X11 and X12: CAN, RS232, RS485

Pin #	Name	Description
1	GND	Digital Ground
2	RS232_RX	RS232 input (receive at product)
3	RS232_TX	RS232 output (transmit from product)
4	RS485_B	RS485 bus, inverted
5	RS485_A	RS485 bus, not inverted
6	Sync	Reserved for future use
7	CAN_L	CAN bus, Low
8	CAN_H	CAN bus, High

Connector type	RJ45 LAN 10/100Base-T connector
Mating connector options	Any CAT5e compatible shielded connector
Cable	CAT5e or higher, standard Ethernet straight cable
Wiring	26 AWG, insulation rated for 100 V



Dual port connector

The serial port is a dual-port RJ45 connector. The two ports have identical pinouts and are interchangeable. Two ports are provided to support daisy chain connection of a CAN bus or RS485. It can be also used to connect two types of communication channels at the same time, instead of splitting a cable from a single RJ45 connector.



CAN bus and RS485 terminators

The CAN bus lines have an optional 120Ω terminator that is connected/disconnected by DIP switch #1 in the DIP SW interface (on the top panel). Setting dip switch #1 to the ON position connects a 120Ω terminator between CAN_H and CAN_L. The terminator is required only in the last unit in the CAN bus chain.

The RS485 lines have a built-in (not optional) 120Ω terminator. Communication performance may be degraded if too many units are placed on the RS485 chain.

3.4.10 Interface X1: Micro USB

Connector X1 is a Micro-USB communication port.

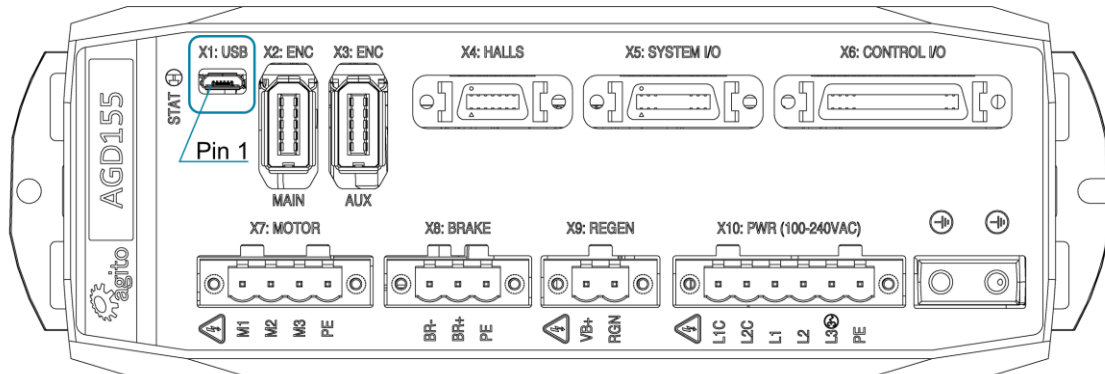

Figure 21: USB Connector

Connector X1: Micro USB

Pin #	Name	Description
1	Vcc	5V
2	D-	Data-
3	D+	Data+
4	ID	USB OTG ID
5	GND	GND

Connector type	Micro-USB 2.0 B
Cable	Any Micro-USB 2.0 B-type cable
Wiring	20 to 28 AWG, insulation rated for 100 V



USB to RS232 bridge

The Micro-USB connection is implemented using an internal converter/adapter from USB to RS232 (UART). Typically, the Windows OS contains a built-in driver for the convertor/adapter. If necessary, you can access drivers at:

<http://www.ftdichip.com/Drivers/D2XX.htm>.

3.4.11 Interface X2: Main Encoder

The X2 encoder port is designed to interface with the main (primary position feedback) encoder for the axis.

This port supports digital quadrature incremental encoders (AqB), analog sin/cos incremental encoders, absolute BiSS-C encoders, and absolute EnDat2.2 encoders. The type of encoder connected to the AGD155 is configured in the Agito PCSuite software.

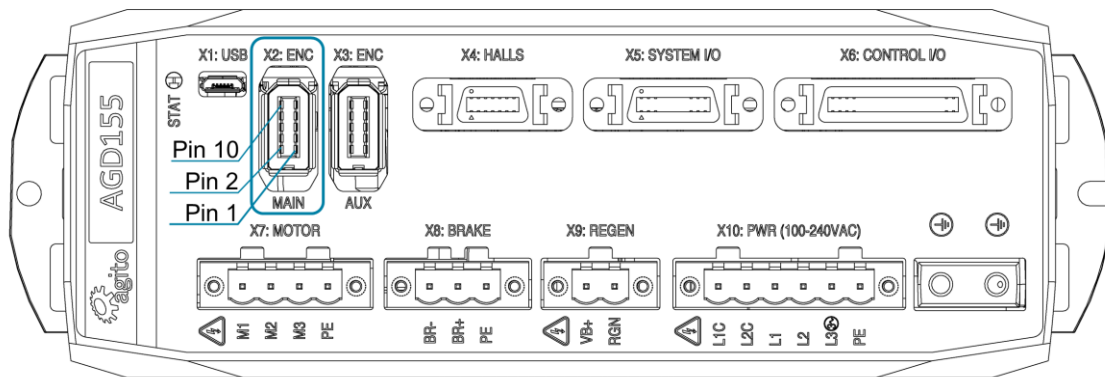

Figure 22. Main Encoder Connector

Connector X2: ENC (MAIN)

Pin #	Name	Encoder Types				Description
		AqB	Sin/Cos	BiSS-C	EnDat 2.2	
1	5V					5V power supply (limited to 0.5A per connector)
2	GND					5V return and reference for differential signals
3	Encoder_1+			CLOCK+	CLOCK+	Clock+ pin for absolute encoders
4	Encoder_1-			CLOCK-	CLOCK-	Clock- pin for absolute encoders
5	Encoder_2+	A+	SIN+			A+ (for AqB) or sin+ (for analog sin/cos)
6	Encoder_2-	A-	SIN-			A- (for AqB) or sin- (for analog sin/cos)
7	Encoder_3+	B+	COS+			B+ (for AqB) or cos+ (for analog sin/cos)
8	Encoder_3-	B-	COS-			B- (for AqB) or cos- (for analog sin/cos)
9	Encoder_4+	Z+	Z+	DATA+	DATA+	Data+ for absolute encoders, or Z+ for both AqB and analog sin/cos encoder
10	Encoder_4-	Z-	Z-	DATA-	DATA-	Data- for absolute encoders, or Z- for both AqB and analog sin/cos encoder

Mating connector options	Sunchu SC-10-4P 3M 36210-0100PL + 36310-3200-008
Wiring	AWG 26, insulation rated for 100 V



Note – Incremental encoder interface details

Each differential-pair includes a built-in 120Ω terminator and the required hardware circuits to detect a disconnected encoder cable. When a disconnected encoder cable is detected, the controller will disable the motor. The detection is done on the A and B channels only (not on the index or Z-channel).

By default, the product does not support single-ended encoder. For use of single-ended encoder, contact Technical Support.



Note – 5V supply limitation

The maximum current available for the encoder is 0.5 A.

3.4.12 Interface X3: Auxiliary Encoder

The X3 encoder port is designed to interface with an auxiliary (second) encoder for the axis.

This port is similar to the main encoder port, supporting digital quadrature incremental encoder, absolute BiSS-C and absolute EnDat2.2 encoder. However, it does not support analog sin/cos encoder input.

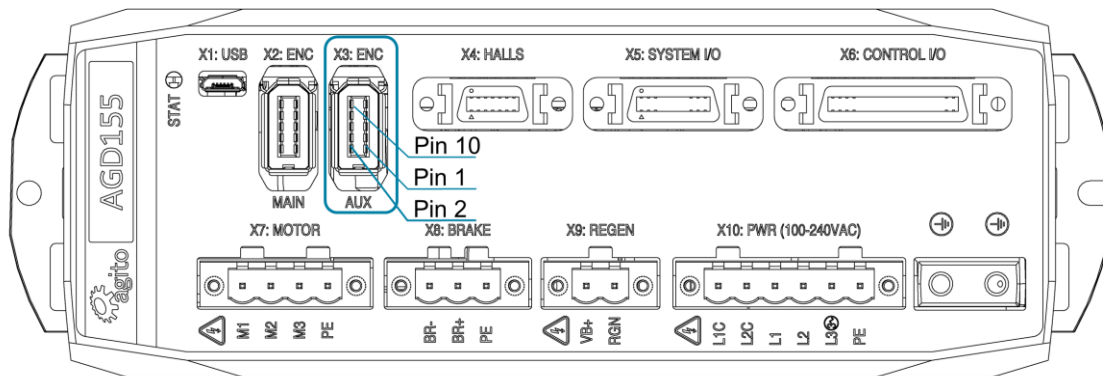

Figure 23 Aux Encoder Connector

Connector X3: ENC (AUX)

Pin #	Name	Encoder Types			Description
		AqB	BiSS-C	EnDat 2.2	
1	5V				5V power supply (limited to 0.5A per connector)
2	GND				5V return and reference for differential signals
3	Encoder_1+		CLOCK+	CLOCK+	Clock+ pin for absolute encoders
4	Encoder_1-		CLOCK-	CLOCK-	Clock- pin for absolute encoders
5	Encoder_2+	A+			A+ (for AqB)
6	Encoder_2-	A-			A- (for AqB)
7	Encoder_3+	B+			B+ (for AqB)
8	Encoder_3-	B-			B- (for AqB)
9	Encoder_4+	Z+	DATA+	DATA+	Data+ for absolute encoders, or Z+ for AqB
10	Encoder_4-	Z-	DATA-	DATA-	Data- for absolute encoders, or Z- for AqB

Mating connector options	Sunchu SC-10-4P 3M 36210-0100PL + 36310-3200-008
Wiring	AWG 26, insulation rated for 100 V



Incremental encoder interface details

Each differential pair includes a built-in 120Ω terminator and the required hardware circuits to detect a disconnected encoder cable. When a disconnected encoder cable is detected, the controller will disable the motor. The detection is done on the A and B channels only (not on the index or Z-channel).

By default, the product does not support single-ended encoder. For use of single-ended encoder, contact Technical Support.



Note – 5V supply limitation

The 5V supply provided at pin 1 of each ENC connector is internally limited to 0.5A.

3.4.13 Interface X4: Hall Sensors

Connector X4 provides the interface for the digital Hall effect sensors and the PT100 temperature sensor from the motor.

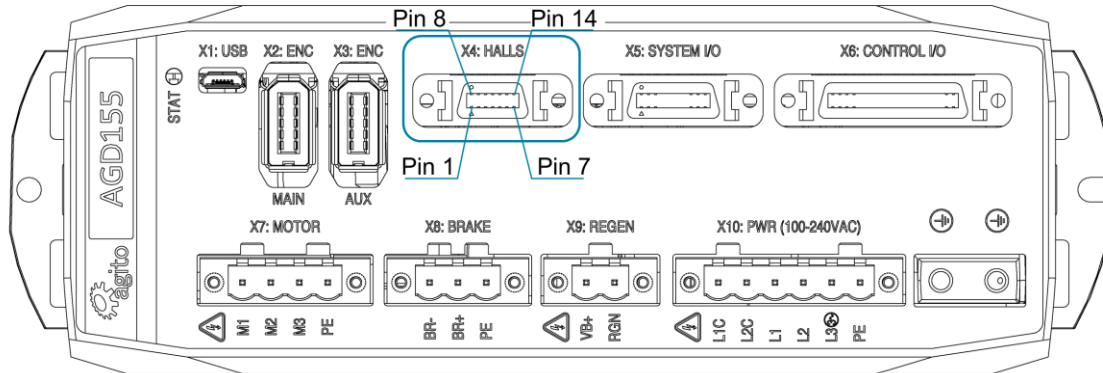

Figure 24. Hall Sensors Connector

Connector X4: HALLS

Pin #	Name	Software Representation	Description
1	5V		5V supply to Hall sensors. Connect to pin 10 when using digital inputs 1 to 3 for Hall sensors.
2	GND		GND for 5V
3	PT1000_EN		For PT1000 temperature sensor, this pin is shorted to pin 6 (GND). For PT100 temperature sensor, this pin is not connected.
4	Digital_Input_1 (Hall_A)	DInPort.bit(0)	Isolated digital input 1 (NPN or PNP, depending on the connection of the group's common pin). To use as Hall input, go to the Agito PCSuite Digital Input page, and configure as Hall A. The following inputs (2 and 3) will be set automatically as Hall B and Hall C.
5	Digital_Input_2 (Hall_B)	DInPort.bit(1)	Isolated digital input 2 (NPN or PNP, depending on the connection of the group's common pin)
6	GND		Do not connect
7	PE		PE
8	RTD+		PT100+ (or PT1000+ if Pin 3 is shorted to pin 6)
9	RTD-		PT100- (or PT1000- if Pin 3 is shorted to pin 6)
10	Digital_Input_Common (1 to 3)		Common pin (power or return, depending on external connection) for digital input 1 to 3
11	Digital_Input_3 (Hall_C)	DInPort.bit(2)	Isolated digital input 3 (NPN or PNP, depending on the connection of the group's common pin)
12	Digital_Input_4	DInPort.bit(3)	Isolated digital input 4, PNP only. For a thermostat input, one end is connected to IO_RTN, the other end is connected here

Pin #	Name	Software Representation	Description
13	IO_PWR		Internally connected to connector X14: I/O PWR pin 1
14	IO_PWR_Return		Internally connected to connector X14: I/O PWR pin 2

Mating connector options	Sunchu SC-14-3 3M 10114-3000PE + 10314-52A0-008
Wiring	AWG 26, insulation rated for 100 V



Note – 5V supply limitation

The 5V supply provided at pin 1 is limited to 0.5A per connector. The maximum total current provided by all the 5V pins in the product is limited to 1.5A.

Hall Sensor Circuitry

Motor Hall sensors can be connected to opto-isolated digital inputs 1, 2, and 3 on connector X4 (HALLS). In Agito PCSuite the first input must be configured to mode 23-Hall A.

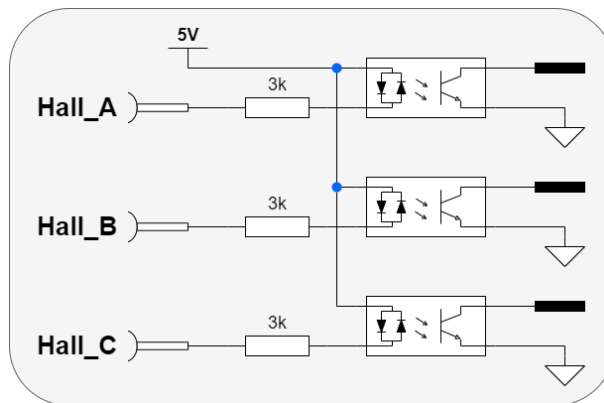

Figure 25. Hall sensors

- It is recommended that Hall sensors be used with incremental encoders. Typically, Hall sensors are called Ha Hb Hc, or Hu Hv Hw, or H1 H2 H3, which correspond to the motor phases. A typical Hall sensor is an open collector (NPN) type and requires a 5 VDC power supply.
- Motor Hall sensors are wired as standard digital inputs.

3.4.14 Interface X5: System I/Os

Connector X5 provides the interface for I/O devices, such as a limit sensor and home switch, which are typically mounted on the actuator or on the machine.

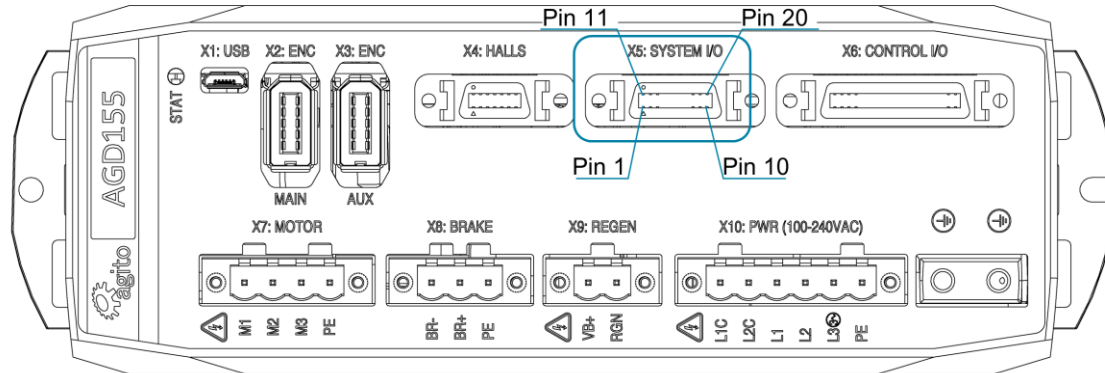

Figure 26. System I/O Connector

Connector X5: SYSTEM I/Os

Pin #	Name	Software Representation	Description
1	Digital_Input_12	DInPort.bit(11)	Isolated digital input 12 (NPN or PNP, depending on the connection of the group's common pin)
2	Digital_Input_14	DInPort.bit(13)	Isolated digital input 14 (NPN or PNP, depending on the connection of the group's common pin)
3	Digital_Input_16	DInPort.bit(15)	Isolated digital input 16 (NPN or PNP, depending on the connection of the group's common pin)
4	Digital_Output_5	DOutPort.bit(4)	Isolated digital output 5, programmable sink or source
5	Digital_Output_6	DOutPort.bit(5)	Isolated digital output 6, programmable sink or source
6	Analog_Input_2	AInPort[2]	Analog input 2, $\pm 12V$ full scale
7	Analog_Input_Return_2		Analog input 2, return
8	Bi-Dir_Diff_IO_1+	DInPort.bit(19) DOutPort.bit(10)	Bi-directional differential I/O + Software configurable: BiDirConfig.bit0 = 0 for input BiDirConfig.bit0 = 1 for output
9	Bi-Dir_Diff_IO_1-		Bi-directional differential I/O -
10	GND		Ground
11	Digital_Input_Common (12 to 16)		Common pin (power or return, depending on external connection) for digital inputs 12 to 16
12	Digital_Input_13	DInPort.bit(12)	Isolated digital input 13 (NPN or PNP, depending on the connection of the group's common pin)

Pin #	Name	Software Representation	Description
13	Digital_Input_15	DInPort.bit(14)	Isolated digital input 15 (NPN or PNP, depending on the connection of the group's common pin)
14	Digital_Output_Common_Power (5 to 6)		Common power pin for isolated digital outputs 5 to 6
15	Digital_Output_Common_Return (5 to 6)		Common power return pin for isolated digital outputs 5 to 6
16	Analog Output 1	AoutPort[1]	Analog output 1, $\pm 12V$ full scale
17	Analog Output 2	AoutPort[2]	Analog output 2, $\pm 12V$ full scale
18	GND		Ground
19	IO_PWR		Connected internally to connector X14: I/O PWR pin 1
20	IO_PWR_Return		Connected internally to connector X14: I/O PWR pin 2

Mating connector options	Sunchu SC-20-3 3M 10120-3000PE + 10320-52A0-008
Wiring	AWG 26, insulation rated for 100 V

3.4.15 Interface X6: Control I/Os

Connector X6 includes a typical set of I/Os (digital isolated, fast differential, and analog) for operation with an external controller by means of $\pm 10V$ analog commands or digital pulse and direction commands.

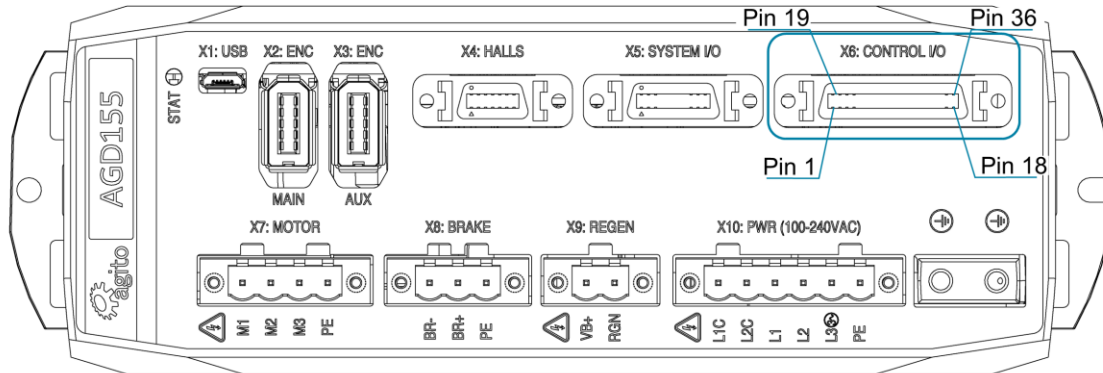

Figure 27: Control I/O Connector

Connector X6: CONTROL I/O

Pin #	Name	Software Representation	Description
1	Differential_Output_1+	DOutPort.bit(6)	Differential output 1+ Emulated encoder A+
2	Differential_Output_1-		Differential output 1- Emulated encoder A-
3	Differential_Output_3+	DOutPort.bit(8)	Differential output 3+ Emulated encoder Z+
4	Differential_Output_3-		Differential output 3- Emulated encoder Z-
5	GND		GND for the differential I/Os
6	Analog_Input_1	AInPort[1]	Analog Input 1, +/-12V full scale
7	Analog_Input_Return_1		Analog input 1 return
8	Differential_Input_2+	DInPort.bit(17)	Differential input 2+ Direction input+ Encoder follower B+ Handwheel B+
9	Differential_Input_2-		Differential input 2- Direction input- Encoder follower B- Handwheel B-
10	GND		GND for the differential I/Os
11	Digital_Input_5	DInPort.bit(4)	Isolated digital input 5 (NPN or PNP, depending on the connection of the group's common pin)
12	Digital_Input_7	DInPort.bit(6)	Isolated digital input 7 (NPN or PNP, depending on the connection of the group's common pin)
13	Digital_Input_9	DInPort.bit(8)	Isolated digital input 9 (NPN or PNP, depending on the connection of the group's common pin)
14	Digital_Input_11	DInPort.bit(10)	Isolated digital input 11 (NPN or PNP, depending on the connection of the group's common pin)
15	Digital_Output_1	DOutPort.bit(0)	Isolated digital output 1, programmable sink or source
16	Digital_Output_Common_Power (1 to 4)		Common power pin for isolated digital outputs 1 to 4

Pin #	Name	Software Representation	Description
17	Digital_Output_Common_Return (1 to 4)		Common power return pin for isolated digital outputs 1 to 4
18	GND		GND for the differential I/Os
19	Differential_Output_2+	DOutPort.bit(7)	Differential output 2+ Emulated encoder B+
20	Differential_Output_2-		Differential output 2- Emulated encoder B-
21	Differential_Output_4+	DOutPort.bit(9)	Differential output 4+
22	Differential_Output_4-		Differential output 4-
23	GND		GND for the differential I/Os
24	Differential_Input_1+	DInPort.bit(16)	Differential input 1+ Pulse input+ Encoder follower A+ Handwheel A+
25	Differential_Input_1-		Differential input 1-; Pulse input- Encoder follower A- Handwheel A-
26	Differential_Input_3+	DInPort.bit(18)	Differential input 3+
27	Differential_Input_3-		Differential input 3-
28	GND		GND for the differential I/Os
29	Digital_Input_Common (5 to 11)		Common pin (power or return, depending on external connection) for digital input 5 to 11
30	Digital_Input_6	DInPort.bit(5)	Isolated digital input 6 (NPN or PNP, depending on the connection of the group's common pin)
31	Digital_Input_8	DInPort.bit(7)	Isolated digital input 8 (NPN or PNP, depending on the connection of the group's common pin)
32	Digital_Input_10	DInPort.bit(9)	Isolated digital input 10 (NPN or PNP, depending on the connection of the group's common pin)
33	Digital_Output_2	DOutPort.bit(1)	Isolated digital output 2, programmable sink or source
34	Digital_Output_3	DOutPort.bit(2)	Isolated digital output 3, programmable sink or source
35	Digital_Output_4	DOutPort.bit(3)	Isolated digital output 4, programmable sink or source
36	5V		5V output

Mating connector options	Sunchu SC-36-3 3M 10136-3000PE + 10336-52A0-008
Wiring	AWG 26, insulation rated for 100 V



Note – 5V Digital_Output_Common_Power source mode limitation.

When using 5V Digital_Output_Common_Power in source mode, higher current (but less than the absolute maximum value of 250 mA) can be driven. However, the output high voltage will drop significantly. To maintain output high voltage at > 4.5V, limit the current to 60 mA.



Note – 5V Digital_Output_Common_Power source mode limitation.

AGD155 Differential Input_X- and Differential_Output_X- are not GND. They must be connected to the negative (-) side of a differential pair in the customer's machine electronics.

3.4.16 I/O Interfaces – Circuitry

Isolated Digital Inputs 1 to 3, 5 to 9, and 12 to 16

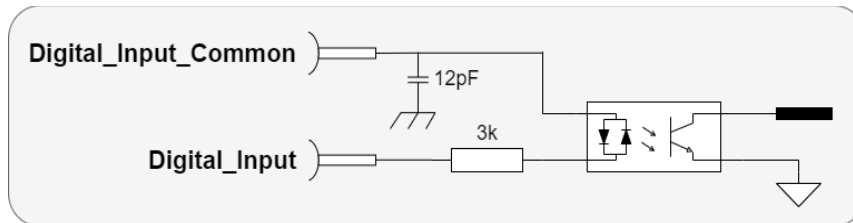

Figure 28. Digital Input 1 to 3, 5 to 9, and 12 to 16 (3 isolated groups)

- The interface circuit is identical for all 8 digital inputs, except Digital_Input_4. Refer to the electrical interface of Digital_Input_4.
- Digital_Input_Common are grouped by digital inputs 1 to 3, 5 to 9, and 12 to 16. Digital_Input_4 is not a part of these groups.
- Each group is fully isolated and independent of the other groups.
- Each group can be connected as NPN or PNP interfaces, depending on the wiring of the group's Digital_Input_Common pin. If the Digital_Input_Common pin is connected to power (between 5V and 24V), then the inputs of this group can be used with external NPN devices (external current sinking devices). If the Digital_Input_Common is connected to the GND of an external power supply, then the inputs of this group can be used with external PNP devices (external current sourcing devices).
- The input circuit of the opto-couplers includes two diodes. This enables use as NPN or PNP.
- One group can be wired to interface external NPN devices and another group can be wired to interface PNP devices. However, within a group, all interfaces (NPN or PNP) must be the same, as they are based on the connection of the group's Digital_Input_Common pin.

Isolated Digital Input 4

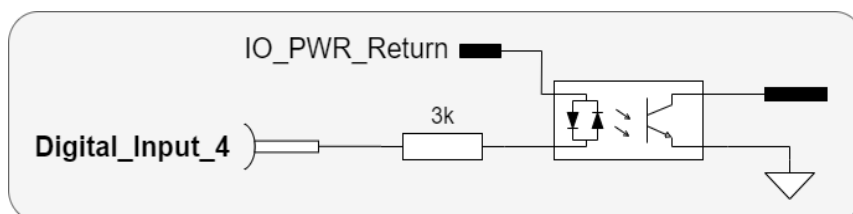

Figure 29. Digital Input 4

- Digital_Input_4 is internally pulled to IO_PWR_Return. It can only be connected as sinking input.

Isolated Digital Outputs 1 to 2, and 3 to 6

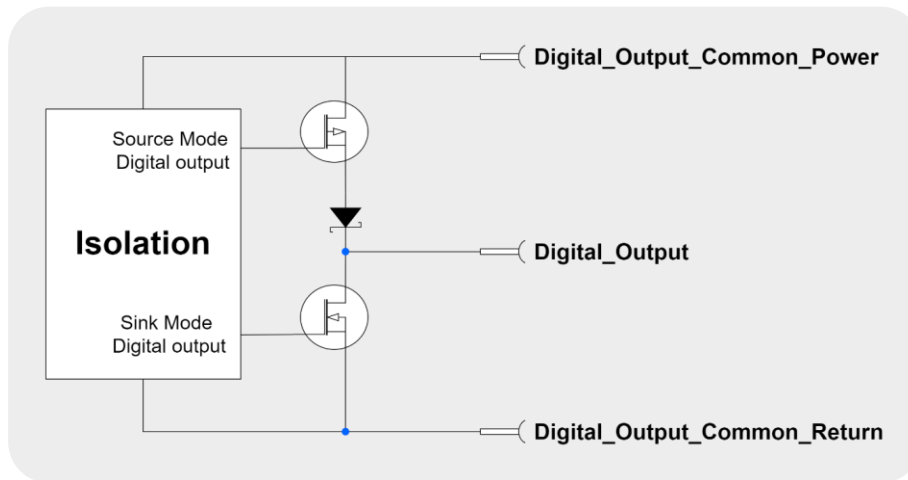

Figure 30. Digital Output 1 to 2, and 3 to 6 (2 isolated groups)

- The interface circuit is identical for all outputs.
- Each output can be programmed (by software parameter) to act as a current sourcing output (up to 300mA), or as a current sinking output (up to 500mA).
- Digital_Output_Common_Power is organized into two groups – digital output 1 to 2, and digital output 3 to 6.
- The outputs are designed for resistive loads. For inductive loads, an external flyback diode is required.
- Digital outputs specifications:
 - Digital_Output_Common_Power voltage range is between 5V and 28V.
 - Maximal load current, per each output:

Sink mode, any Digital_Output_Common_Power voltage:	500 mA
Source mode, at 24V Digital_Output_Common_Power:	300 mA
Source mode, at 5V Digital_Output_Common_Power:	60 mA (see Note below)



Note – 5V Digital_Output_Common_Power source mode limitation.

When using 5V Digital_Output_Common_Power in source mode, higher current (but less than the absolute maximum value of 250 mA) can be driven. However, the output high voltage will drop significantly. To maintain output high voltage at > 4.5V, limit the current to 60 mA.

Differential Inputs 1 to 3

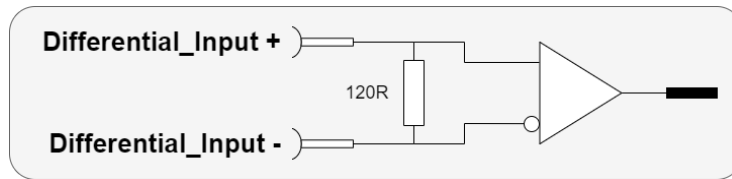

Figure 31. Differential Inputs 1 to 3

- Dedicated digital ground: GND (pin 10 connector X6) must be connected to GND of the controller/PLC. PE is not used for digital ground.
- Each differential input has a 120 Ω terminator.
- Each differential input has a pull-up to 3.3V on its positive pin, and a pull-down to GND on its negative pin. This ensures that the input is not floating when not connected and that its reading is known and fixed.
- The negative input pin on each differential input also has also a pull-up to 3.3V. This enables use of a differential input with a single-ended source, by connecting it to the positive input only and leaving the negative pin disconnected.
- The differential inputs can be used with 5V differential sources.

Differential Outputs 1 to 4

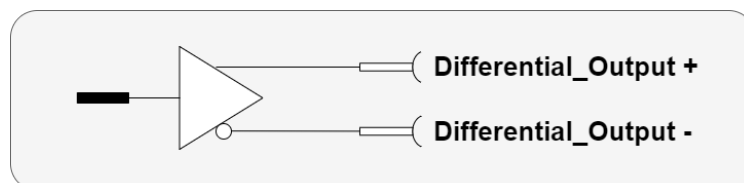

Figure 32. Differential Outputs 1 to 4

- Dedicated digital ground: GND (pin 10 connector X6) shall be connected to controller/PLC GND. PE is not used for digital ground.
- The differential outputs are inactive during power on, until they are controlled by the drive firmware and the user parameters.

Bi-Directional Differential I/O

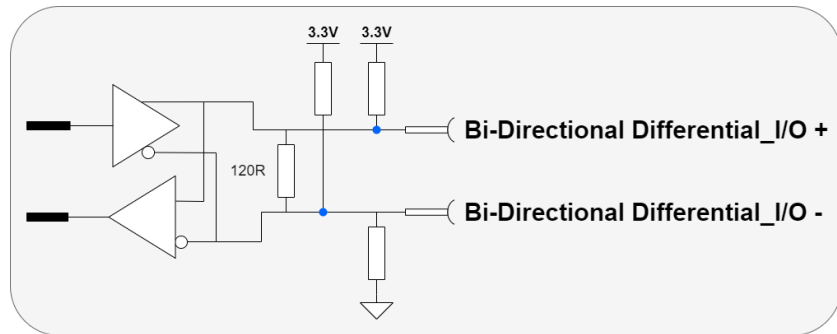

Figure 33. Bi-Directional Differential I/O

- Dedicated digital ground: GND (pin 10 connector X6) must be connected to GND of the controller/PLC. PE is not used for digital ground.
- The bi-directional differential output is configurable by software to be differential output or differential input.
- Both + and - pins are pulled up to 3.3V.
- There is a 120Ω termination resistor between the + and - pins.

Analog Inputs 1 to 2

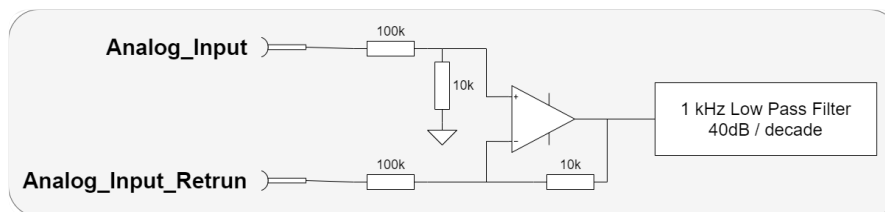

Figure 34. Analog Inputs 1 to 2

- The electrical interfaces of all analog inputs are identical.
- The analog input range is -12V to +12V, and resolution is 16 bits.
- The analog input is designed for standard differential analog input, with a simple input circuit, having an input resistance of $\sim 60\text{ k}\Omega$.
- For single-ended analog inputs, be sure to connect the return line to GND. Do not leave it unconnected.
- Input circuit bandwidth is 1 kHz, -40 dB/decade.
- The controller software provides the following parameters to control the analog input reading:
 - Filter
 - Offset
 - Deadband
 - Gain

Analog Outputs 1 to 2

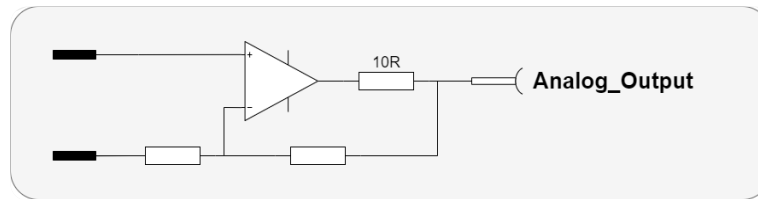

Figure 35. Analog Outputs 1 to 2

- The electrical interfaces of all analog outputs are identical.
- The analog output range is from -12V to +12V, with resolution of 16 bits.
- Output resistance is 10Ω.
- Output current is up to ±2mA, without internal current limitation.
- Analog outputs are controlled by the controller software in few operational modes:
 - Analog output controlled by the user program for general purpose usage.
 - Analog output reflects the internal value of a user selected parameter (position, position error, velocity, current, or any parameter/status of the controller), with a user defined scaling factor, for easy monitoring using an external oscilloscope.

4 Operation

4.1 Motor Configuration

This manual uses the product with a linear DC brushless motor as an example for illustration of the configuration and operation. For advanced configuration and operation, refer to the respective software manuals.

1. Connect the product to power supply, motor, encoder and other I/Os according to the descriptions in the *Electrical Interfaces* section.

Make sure the safety port is connected before any operation.

2. Open Agito PCSuite software. Select CFG in CONFIG below and setup the parameters as follows:

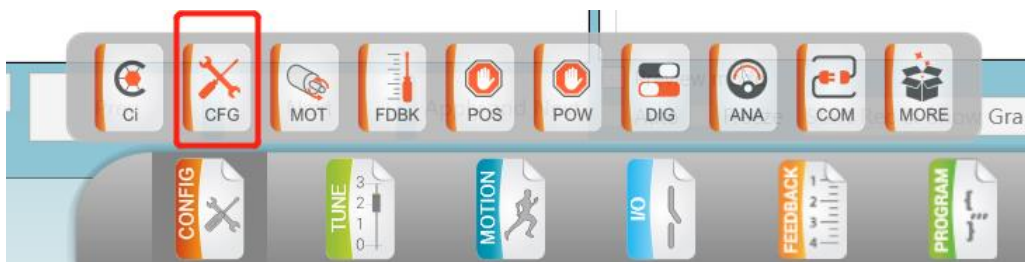

Figure 36. Configuration

Basic Configuration	
System	
Operation mode:	3 - Position control
<small>The controller supports multiple methods for on-the-fly mode switching. Please refer to the most updated User's Manual.</small>	
Amplifier type:	0 - Built In PWM amplifier (DRV produ
Power supply:	1 - Single phase
Static brake	<input type="checkbox"/> Use
Static brake mode:	2 - Manual Release Command – without Protec
Brake lock time:	100
Brake release time:	100 msec
Dynamic brake	<input checked="" type="checkbox"/> Use
Speed threshold:	2,000 user-units/sec
Regeneration	<input type="checkbox"/> Use
Activate at:	360,000 mV
Deactivate at:	340,000 mV

Figure 37. Operation Mode Configuration

3. Click **Next** and set the motor type and number of pole pairs according to the test motor.

Motor	
Motor Parameters	
Type:	3 - Linear DC Brushless
Number of pole pairs:	1

Figure 38. Select Motor Type

4. Click **Next** to setup the position feedback parameters. The definition of **Resolution** depends on the motor and encoder type. For rotary motor and rotary encoder, it is the number of encoder counts per mechanical revolution. For linear motor, it is the number of encoder counts per magnetic pitch (one pole-pair).

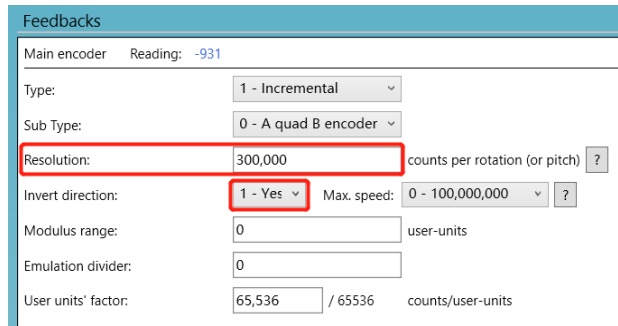

Figure 39. Feedback Parameters

The value of **Invert direction** affects commutation of the motor. The encoder must be moving in the positive direction during auto-phasing process.

5. Click **Next** to setup position, velocity and motor stuck protection. Fill in the limits according to the application requirements.

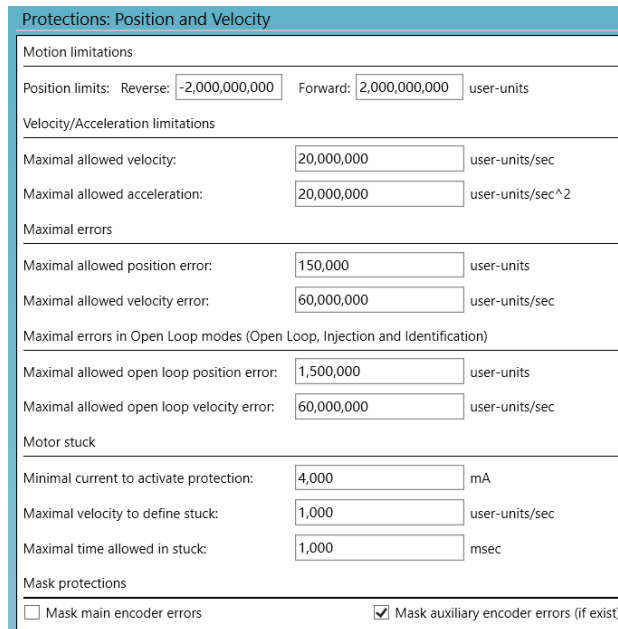

Figure 40. Position and Velocity Protection

6. Click **Next** to configure current and voltage limits. It is important to refer to motor’s specifications. The limits entered here must be within the motor operating limits to avoid damaging the motor.

Protections: Power and Current	
Current limitations and protections Current units ?	
Continuous limitation:	1,000 mA
Peak limitation:	5,000 mA
Peak maximum time:	1,000 msec
Maximal phase current:	4,750 mA
Maximal allowed motor current:	4,750 mA
<i>Current protections should be higher than Peak limitation</i>	
Maximal allowed power unit temperature:	65 °C
Motor temperature sensor (PT100):	<input type="checkbox"/> Connected
Maximal allowed motor temperature:	80 °C
Bus voltage protections	
Minimal allowed bus voltage:	150,000 mV
Maximal timed bus voltage:	360,000 mV
Maximal time for over voltage:	0 ms
Absolute maximal allowed bus voltage:	360,000 mV
PWM limitations	
PWM limitations:	90 %

Figure 41. Current and Voltage Protection

4.2 Drive/Motor Overload Protection

The following methods are used to protect the AGD155 from overload:

- I^2T
- Motor stuck
- Motor temperature protection using a PT100 or PT1000.

4.2.1 I^2T Overload Protection

In a transient condition, the motor can sustain a certain amount of energy that exceeds the continuous limit. However, the more the current value exceeds the continuous current, the less time the current value can be sustained, and vice versa.

If the maximal energy level is surpassed, the maximal current is limited to the continuous current, instead of being limited to the peak current as usual.

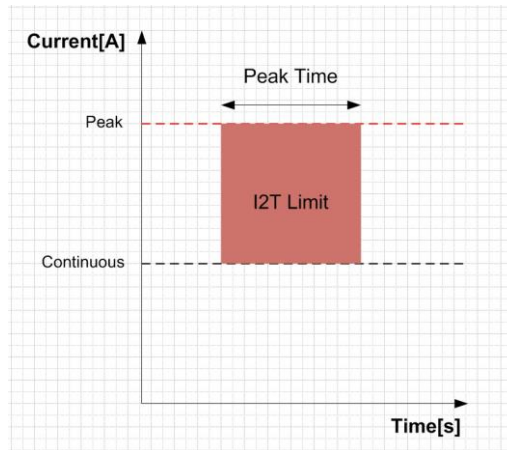

Figure 42. I^2T

In Agito PCSuite, the following parameters define the I^2T characteristics:

- Peak current
- Continuous current
- Peak time

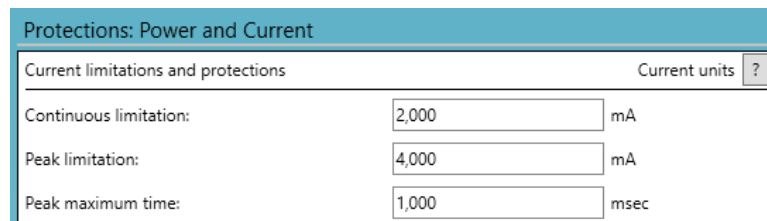

Figure 43. I^2T Settings



Note – The I²T algorithm does not support thermal memory protection or thermal memory during power loss.

On drive power-up, the algorithm does not consider the amount of energy supplied to the motor prior to power-up.



Note – The I²T algorithm does not consider motor speed. Therefore, the product does not support thermal speed sensitivity.

4.2.2 Motor Stuck

Motor stuck indicates whether or not the motor is in fact stuck. The condition is strongly dependent on the application.

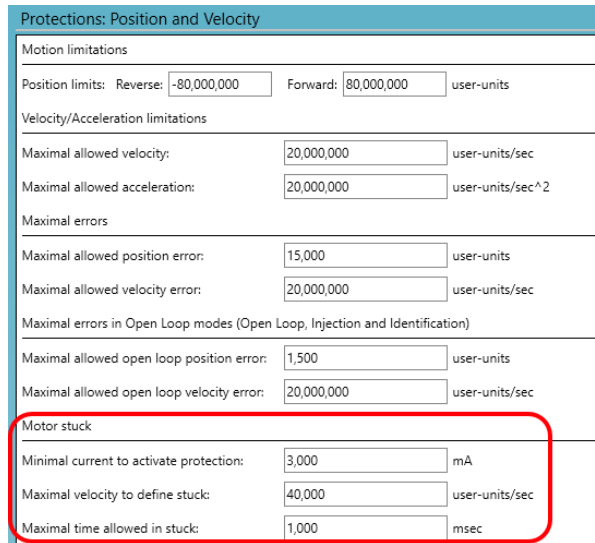

Protections: Position and Velocity	
Motion limitations	
Position limits: Reverse:	-80,000,000 user-units
Forward:	80,000,000 user-units
Velocity/Acceleration limitations	
Maximal allowed velocity:	20,000,000 user-units/sec
Maximal allowed acceleration:	20,000,000 user-units/sec ²
Maximal errors	
Maximal allowed position error:	15,000 user-units
Maximal allowed velocity error:	20,000,000 user-units/sec
Maximal errors in Open Loop modes (Open Loop, Injection and Identification)	
Maximal allowed open loop position error:	1,500 user-units
Maximal allowed open loop velocity error:	20,000,000 user-units/sec
Motor stuck	
Minimal current to activate protection:	3,000 mA
Maximal velocity to define stuck:	40,000 user-units/sec
Maximal time allowed in stuck:	1,000 msec

Figure 44. Motor Stuck Settings

The protection feature monitors and responds to a condition in which the amplifier is providing a certain amount of minimal current (StuckCurr), but the motor does not move at the minimal expected speed (StuckVel) for a certain amount of time (StuckTime). If this condition occurs, the motor will be shut off.

4.2.3 Motor Temperature Protection

If the motor temperature sensor option is selected, the AGD155 will monitor the PT100/1000 temperature sensor readings, and display warnings in the status window if the temperature is approaching the specified limit.

If the temperature exceeds the specified limit, the motor will be shut off.

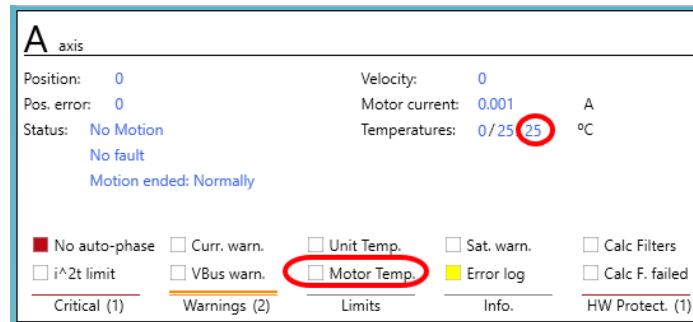

A axis	
Position:	0
Velocity:	0
Pos. error:	0
Motor current:	0.001 A
Status:	No Motion
Temperatures:	0/25 25 °C
	No fault
	Motion ended: Normally
<input checked="" type="checkbox"/> No auto-phase	<input type="checkbox"/> Curr. warn.
<input type="checkbox"/> i^2t limit	<input type="checkbox"/> VBus warn.
<input type="checkbox"/> Unit Temp.	<input type="checkbox"/> Sat. warn.
<input checked="" type="checkbox"/> Motor Temp.	<input type="checkbox"/> Calc Filters
<input type="checkbox"/> Error log	<input type="checkbox"/> Calc F. failed
Critical (1)	Warnings (2)
Limits	Info.
	HW Protect. (1)

Figure 45. Axis Status

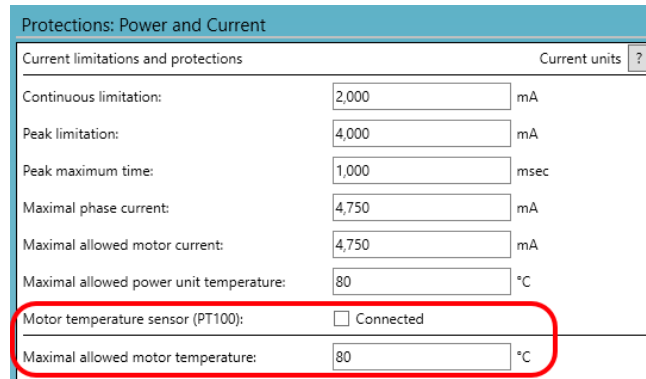

Protections: Power and Current	
Current limitations and protections Current units ?	
Continuous limitation:	2,000 mA
Peak limitation:	4,000 mA
Peak maximum time:	1,000 msec
Maximal phase current:	4,750 mA
Maximal allowed motor current:	4,750 mA
Maximal allowed power unit temperature:	80 °C
Motor temperature sensor (PT100):	<input checked="" type="checkbox"/> Connected
Maximal allowed motor temperature:	80 °C

Figure 46. Motor Temperature Settings

4.3 Tuning

4.3.1 Commissioning



This step is required only for brushless motor.

Select TUNE > PHAS. in the tune option.

Configure the main encoder resolution. For Auto-Phasing mode, select **Automatic upon power on** if the application allows “shake and wake” upon power up. If not, select **Automatic upon MotorOn (if needed)** to “shake and wake” only when the motor is ready for motor on.

Use **Jump to zero phase** for Auto-Phasing method for most reliable result. This method requires the longest search distance.

If the stroke does not allow such search distance, select **Minimal Motion** method.

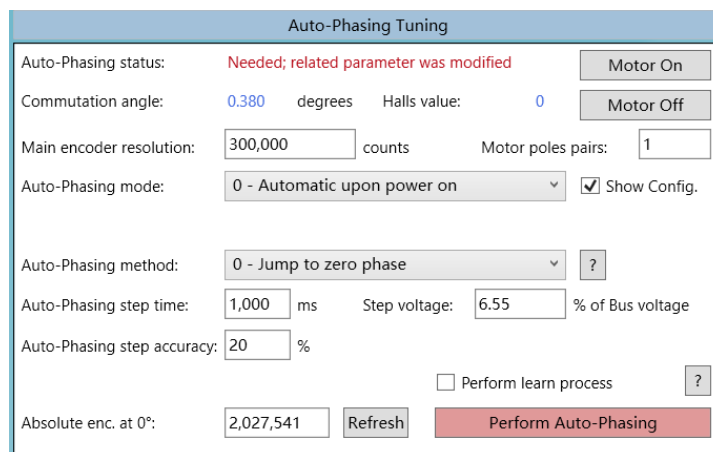

Auto-Phasing Tuning	
Auto-Phasing status:	Needed; related parameter was modified Motor On
Commutation angle:	0.380 degrees Halls value: 0 Motor Off
Main encoder resolution:	300,000 counts Motor poles pairs: 1
Auto-Phasing mode:	0 - Automatic upon power on <input checked="" type="checkbox"/> Show Config.
Auto-Phasing method:	0 - Jump to zero phase ?
Auto-Phasing step time:	1,000 ms Step voltage: 6.55 % of Bus voltage
Auto-Phasing step accuracy:	20 % <input type="checkbox"/> Perform learn process ?
Absolute enc. at 0°:	2,027,541 Refresh Perform Auto-Phasing

Figure 47. Auto-Phasing for Brushless motor

If the system does not allow any motion during power-on or motor-on, use Hall sensors for commutation phasing.

1. Connect Hall sensors to HALLS port and configure the first of the three inputs in the digital I/O page as **Hall A**.
2. Use the **Jump to zero phase** method to establish the motor and Hall phases; select **Perform learn process** and click **Perform Auto-Phasing**.

- After the auto-phasing is completed successfully, change the Auto-Phasing method to **Encoder with Halls/Encoder switching** and save all parameters to flash. After reset or power cycle of the controller, auto-phasing will be done by Hall sensors.

Figure 48. Using Hall Sensors to Avoid "Shake and Wake"

4.3.2 Current Loop Tuning

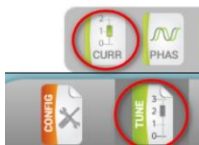

Select TUNE > CURR.

Enter motor's phase resistance and phase inductance according to the motor's datasheet and enter the desired current loop bandwidth for this axis. Typically, 1000 Hz is suitable for most applications.

Click **Calculate PI** to calculate the current loop gains.

Check both checkboxes for auto data recording and user predefined data recording.

Click **Apply Current Command** to test the current loop performance.

Figure 49. Current Loop Tuning

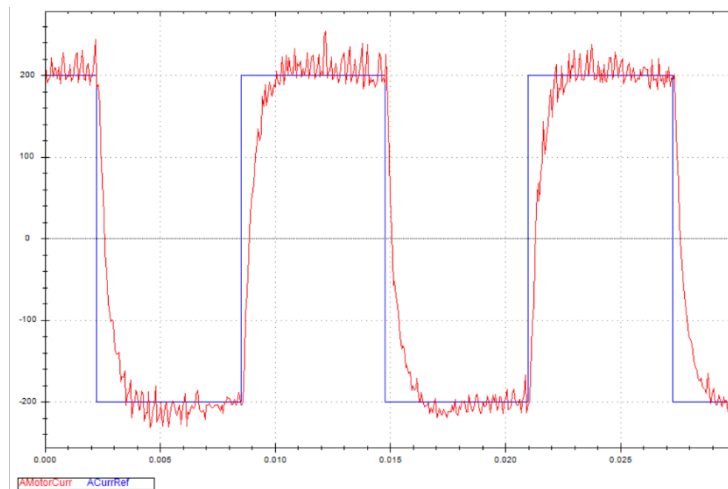

Figure 50 Typical Current Loop Performance

4.3.3 Auto Velocity and Position Loop Tuning

1. System Identification.

Select TUNE > IDEN.

Click **Begin Identification** to perform system identification.

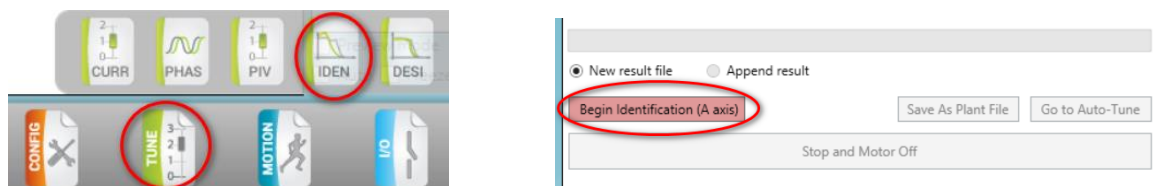

Figure 51. Begin System Identification

When the identification is completed successfully, the plant's transfer function will be displayed, as shown in the following figure.

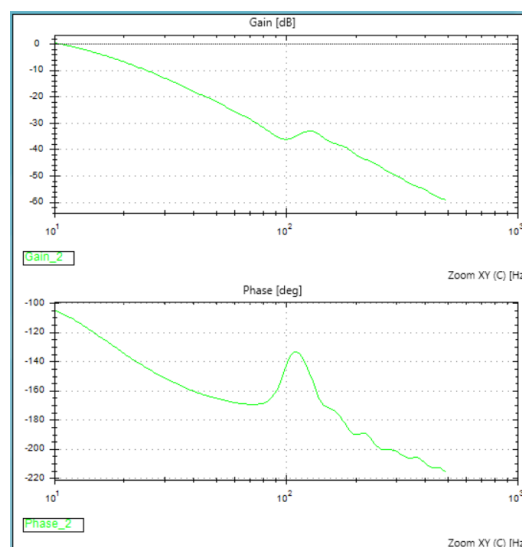

Figure 52. Typical Plant Transfer Function

Tuning

- Click **Go to Auto-Tune**. Alternatively, select TUNE-> DESI to open the Auto-Tuning (controller design) page.

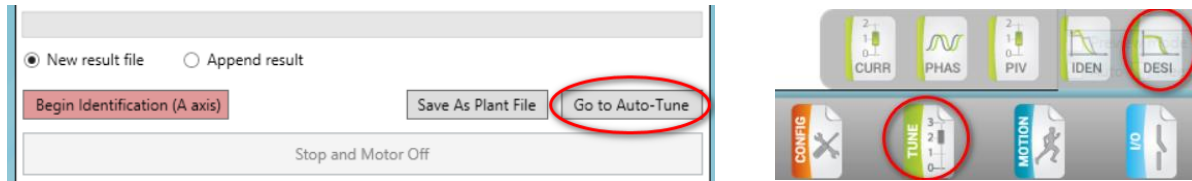

Figure 53. Go to Auto-Tuning page

- Click Run Auto-Tune to start Auto-Tuning. It will take a few seconds, or longer for more complex systems, to calculate the optimum PIV gains for this plant.

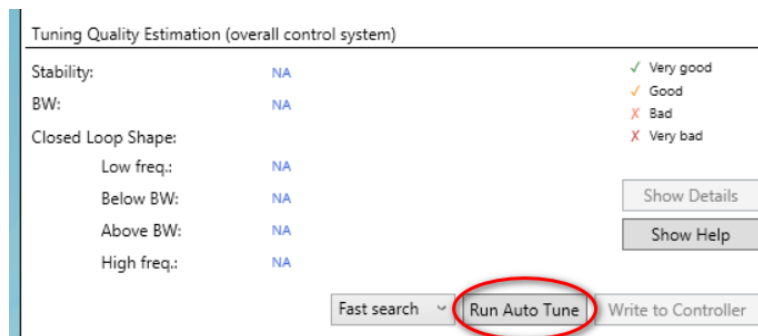

Figure 54. Start Auto-Tuning calculation

- Once Auto-Tuning is completed, click **Write to Controller** to download the calculated gains into the controller.

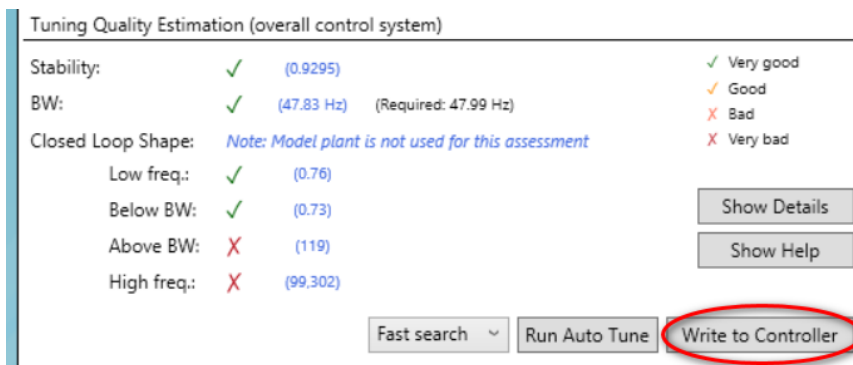
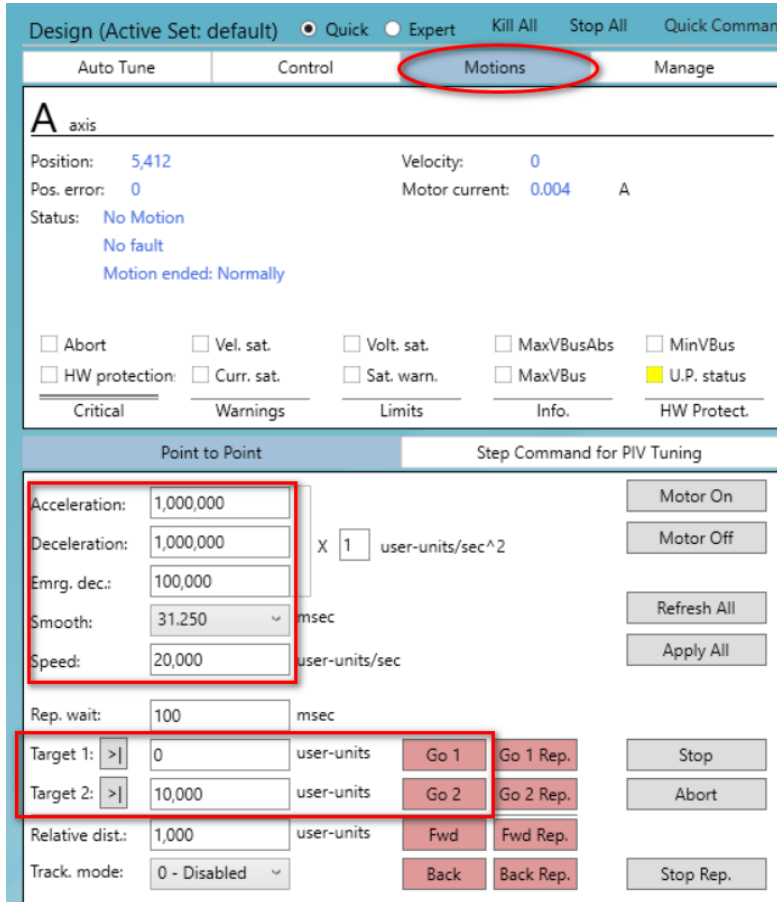

Figure 55. Download the parameters to the controller

Tuning

5. Check the motion performance in the Motions Tab, set the required motion profile, and click **Go 1** or **Go 2** to move to Target 1 or Target 2. Record the motion data to analyze the motion performance in detail.



The screenshot displays the 'Motions' tab for 'A axis'. The status section shows: Position: 5,412; Velocity: 0; Pos. error: 0; Motor current: 0.004 A; Status: No Motion, No fault, Motion ended: Normally. Below the status are checkboxes for Abort, Vel. sat., Volt. sat., MaxVBusAbs, MinVBus, HW protection, Curr. sat., Sat. warn., MaxVBus, and U.P. status. The main configuration area is divided into 'Point to Point' and 'Step Command for PIV Tuning'. The 'Point to Point' section has a red box around the following settings: Acceleration: 1,000,000; Deceleration: 1,000,000; Emrg. dec.: 100,000; Smooth: 31.250 msec; Speed: 20,000 user-units/sec. The 'Step Command for PIV Tuning' section has a red box around the target settings: Target 1: >| 0 user-units; Target 2: >| 10,000 user-units. Other settings include Rep. wait: 100 msec, Relative dist.: 1,000 user-units, and Track. mode: 0 - Disabled. Buttons for Motor On/Off, Refresh All, Apply All, Stop, Go 1, Go 2, Go 1 Rep., Go 2 Rep., Fwd, Fwd Rep., Back, Back Rep., and Stop Rep. are also visible.

Figure 56. Testing Motion

4.3.4 Manual Velocity and Position Loop Tuning



Select TUNE > PIV.

Adjust the proportional (PI, gain) and integral (PI, integral) gains of velocity loop.

Click **Apply Vel Command** to check the performance.

PIV Tuning	Pos Filters	Vel Filters	Scheduling	PTP	Step...
Refer to Sched. Tab Scheduling: None Motor On					
Position: 1 Motor Off					
Gain: 83					
Accel. FFW: 0					
Vel. FFW: 0					
Velocity: <input type="checkbox"/> Use PID tuning					
PI, gain: 740 Vel. track factor: 100 %					
PI, integral: 283 Vel. FFW filter: 10,000 Hz					
<input type="checkbox"/> Perform auto data recording					
<input type="checkbox"/> Use predefined data recording setting					
Apply Pos Command		Apply Vel Command		Disable Commar	

Figure 57. Manual Velocity Loop Tuning

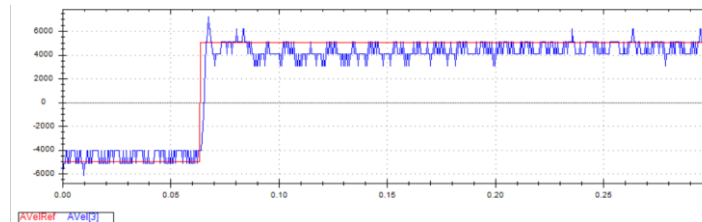

Figure 58. Typical Velocity Loop Performance

Similarly, adjust proportional gain of position loop.

In addition, adjust acceleration and velocity feedforward to improve performance.

Click **Apply Pos Command** to check performance.

PIV Tuning	Pos Filters	Vel Filters	Scheduling	PTP	Step...
Refer to Sched. Tab					
Scheduling: None					
Position:	7				
Gain:	83				
Accel. FFW:	0				
Vel. FFW:	0				
Velocity:					
PI, gain:	740				
PI, integral:	283				
<input type="checkbox"/> Perform auto data recording <input type="checkbox"/> Use predefined data recording setting					
Apply Pos Command		Apply Vel Command		Disable Command	
Motor On		Motor Off		<input type="checkbox"/> Use PID tuning Vel. track factor: 100 % Vel. FFW filter: 10,000 Hz	

Figure 59. Position Loop Tuning

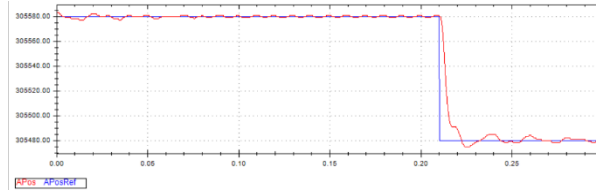

Figure 60. Typical Position Loop performance

Repeat the configuration and tuning steps for all the axes connected to the product.

Finally, test the motion according to the required motion profile, as shown in Figure 56. Testing Motion.

5 Maintenance and Servicing

Troubleshooting

Condition	Potential Cause	Possible Resolution
Power is On but no LED light	Power connector is loose	Check power connector, measure power supply voltage using a voltmeter.
	Firmware is corrupted	Turn on DIP switch #2, power cycle, and download firmware using Agito PCSuite.
Motor is oscillating or out of control (free wheel)	The position feedback sensor (encoder) is faulty or disconnected	Check wiring.
	Position feedback sensor is configured in wrong direction	Go to Agito PCSuite's CONFIG > FDBK page, toggle the Invert direction setting.
	Encoder signal is interfered by EMI noise in the system, resulting in lost counts or incorrect position feedback	Verify if the encoder signal is drifting even when the motor is physically locked or not moving. Check electrical grounding, shielding and PE in the system to ensure there are no ground-loop in the system. Set EncFilt from Agito PCSuite's CONFIG > FDBK page to a frequency setting that is just above the required motion speed.
	Control loops' gains are too high	Go to Agito PCSuite's Tune page, select CURR and/or PIV page to reduce the gains to half. If the situation improved, redo tuning for the axis.
	Velocity or Acceleration command is set too high	Reduce the acceleration, deceleration, smooth and speed setting.
	Noise introduced in calculation of velocity from position feedback	Add a software low pass filter from Agito PCSuite's TUNE > PIV, Velocity Filters tab.
	Mechanical resonance.	Add a software low pass filter from Agito PCSuite's TUNE > PIV, Velocity Filters tab. Do advanced auto tuning to allow Agito PCSuite identify and apply a suitable filter. Perform TUNE > IDEN and TUNE > DESI (Expert > Expert Tune mode for best result).
Cannot achieve the required speed	Acceleration and/or deceleration and/or speed is set too low, or smooth is set too high.	Adjust acceleration, deceleration and smooth settings.
	Current and voltage limits are set too low	Check current limits are according to motor's datasheet and maxPWM, under CONFIG->POW page, is set to between 90% and 95%.
	Improper control loops gains	Re-tune the motor
	The load inertia or friction is too high for the motor	Check motor and driver sizing for this axis to ensure the motor force, current and voltage of power supply is sufficient to achieve the motion.

Condition	Potential Cause	Possible Resolution
	Auto-phasing is inaccurate	Check that hall sensors and encoder signal are functional and not interfered by EMI in the system. And redo auto-phasing.
Motor does not respond to a command	The axis is stopped by FLS/RLS position limit sensor or limited by software position and velocity limits.	Check if FLS and RLS of the motor is active. Or it could be a wrong setting where another sensor is configured wrongly as the FLS or RLS of this motor. Check software position limits and velocity limits at Agito PCSuite's CONFIG > POS page. If the FLS or RLS signal is active when the digital input is changed, the FLS or RLS status will remain ON. In this case, set the digital input to FLS or RLS, manually move the motor away from the sensor before change the digital input function. Alternatively, reset the controller or power cycle the controller.
	The axis is configured in a wrong operating mode or function, e.g. as a slave axis or another master.	Check all motion related configurations.
	Motor connector is loose.	Check motor power connection.
	The motor is faulty.	Measure motor's resistance and inductance at Agito PCSuite's TUNE > CURR page to check if the resistance and inductance values are close to the motor specification.
	If this is an actuator with ballscrew, timing belt or other transmission, the coupling or other mechanical part may be loose.	Check all mechanical transmission parts and mechanism.
	Motor brake is engaged	Check brake wiring and power supply.

